

# MPS1

YÜKSEK PERFORMANS YEKPARE KARBÜR MATKAP



# MPS1

## YÜKSEK PERFORMANSLI YEKPARE MATKAP

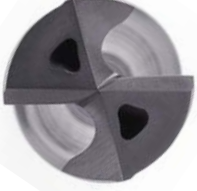

LxDC 3 - 8

### GÜÇLÜ KESME KENARI

Yüksek performanslı delme işlemleri için

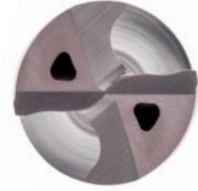

LxDC 10 - 40  
LxDC 2 (PC)

### OPTİMİZE EDİLMİŞ GEOMETRİ

Ekstra derin deliklerin delinmesi ve optimum delik kalitesi için

### DP1021

Yeni ALTiCrN PVD kaplama teknolojisi, standart ve yüksek kesme hızlarında uzun takım ömrü ve yüksek verimlilik sağlar. Çelikte, paslanmaz çelikte ve dökme demirde kullanıma uygundur.

### DOĞRULUK

Çift marj ve Tri-Coolant Teknolojisi yüksek kaliteli delik yüzeyi sağlamaya yardımcı olur.

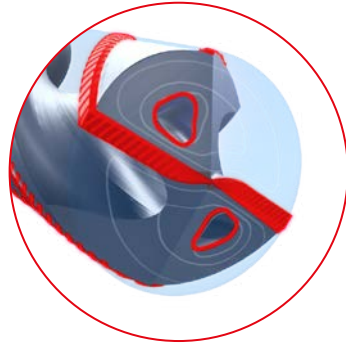

- Arttırılmış soğutma suyu hacmi
- Marjda optimize edilmiş akış
- Daha hızlı yonga boşaltımı

### RİJİDLİK (CAE ANALİZİ)

MPS1 süper uzun matkap, çekirdek çapı ve helis açısı optimize edilerek %20 daha yüksek burulma mukavemeti sağlamak üzere tasarlanmıştır.

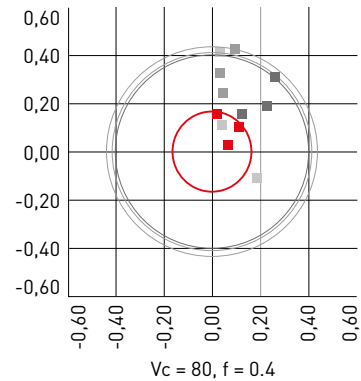
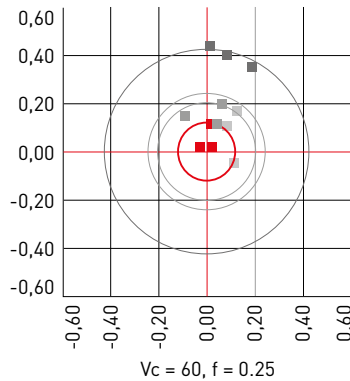

- Mitsubishi Materials Takımı  
■ Geleneksel A ■ Geleneksel B ■ Geleneksel C

# UYGULAMA ÖRNEKLERİ

## STANDART KESİM KOŞULUNDA Ø8 MM TAKIM ÖMRÜ TESTİ

Çalışma malzemesi	DIN C50
Delik derinliği (mm)	40
Vc (m/dak)	120
f (mm/dev)	0.25
Soğutma suyu	W.S.O.
Makine	Dikey M/C
Sonuç	MPS1'in takım ömrü 2,5 kat daha uzun olmuştur.

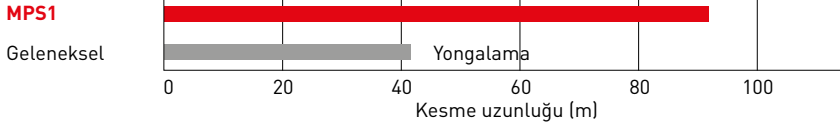

MPS1



Klasik

## YÜKSEK HIZLI KESME KOŞULUNDA Ø8 MM TAKIM ÖMRÜ TESTİ

Çalışma malzemesi	DIN C50
Delik derinliği (mm)	40
Vc (m/dak)	200
f (mm/dev)	0.35
Soğutma suyu	W.S.O.
Makine	Dikey M/C
Sonuç	MPS1'in takım ömrü 4 kat daha uzun olmuştur.

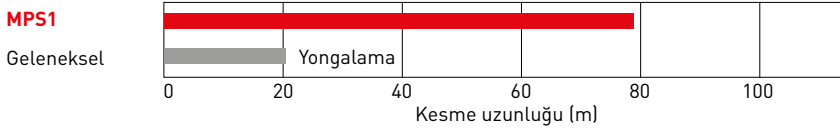

MPS1



Klasik

# SÜPER UZUN MATKAPLAR

## MERKEZE AÇIK DELİK DELİNMESİ

Takım	MPS1-0380-L12C
İş Parçası Malzemesi	115MnPb30
Delik derinliği (mm)	45 (12 l/d)
Vc (m/dak)	75
f (mm/dev)	0.135
Tezgah	Kayar Tip Torna (Swiss).
Sonuç	MPS1'in takım ömrü %36 daha uzun.

**MPS1**

Geleneksel

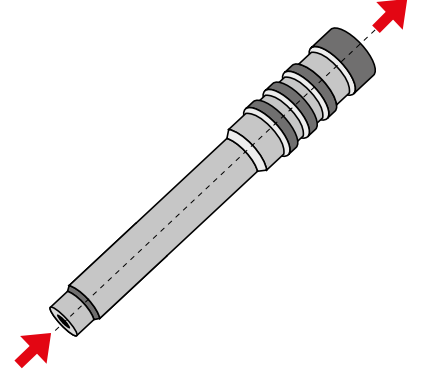
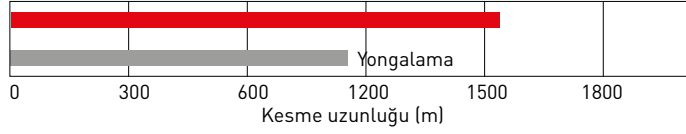

## SOĞUTMA DELİKLERİNİN DELİNMESİ

Takım	MPS1-0800-L30C
İş Parçası Malzemesi	CR7 V-L (Soğuk iş çeliği, 1130 N/mm <sup>2</sup> )
Delik derinliği (mm)	250 (30 l/d)
Vc (m/dak)	120
f (mm/dev)	0.35
Tezgah	Yatay işleme merkezi
Sonuç	MPS1'in takım ömrü 2 kat daha uzun. 0,15 mm'den daha az delik eksenel doğruluğu.

**MPS1**

Geleneksel

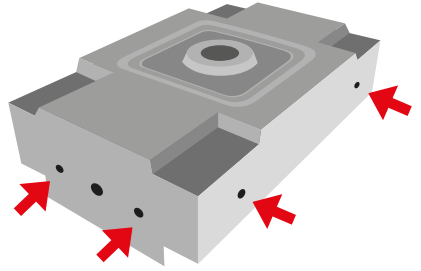
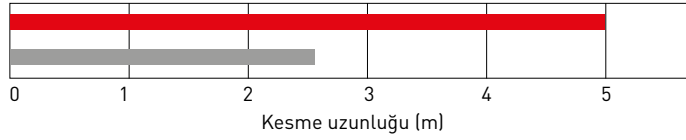

# MPS1

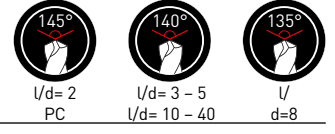

## YEKPARE KARBÜR MATKAP



### 1 Konik boyunlu silindirik şank türü

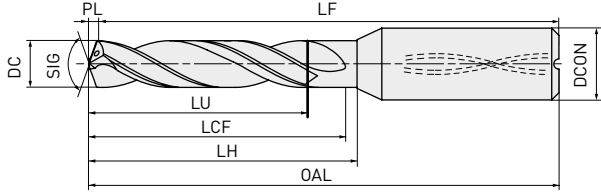

MPS1----S/L-DIN-C/L8C -L40C

### 2 Silindirik şank türü

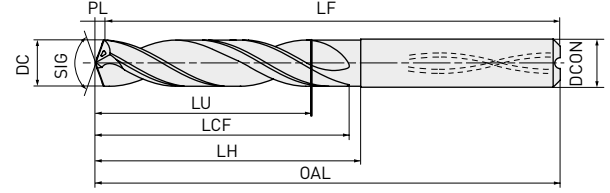

MPS1----S/L-DIN-C/L8C -L40C

### 3 Konik boyunlu düdük çentikli şank türü

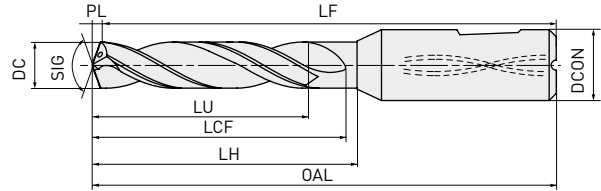

MPS1----S/L-DIN (Düdük Çentikli)

### 4 Düdük çentikli şank türü

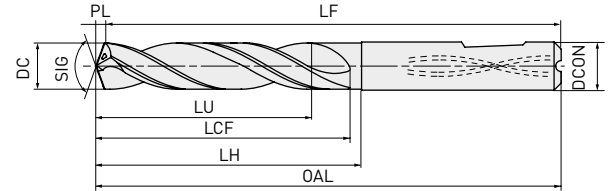

MPS1----S/L-DIN (Düdük Çentikli)

- DC' si 6 mm'ye kadar olan S-DIN (C) & L-DIN (C) & L8C matkaplarda soğutma delikleri yuvarlaktır.  
DC' si 4.9 mm'ye kadar olan L10C - L40C matkaplarda soğutma delikleri yuvarlaktır.
- SIG : l/d 3 - 5, 10 - 40 = 140°, 8 = 135°, PC = 145°



	3≤DC≤6	6<DC≤10	10<DC≤18	18<DC≤20
DC Tolerans (DIN/PC) (mm)	+0.010 -0.002	+0.010 -0.005	+0.005 -0.013	+0.005 -0.016
DC Tolerans (L_C) (mm)	0 -0.012	0 -0.015	0 -0.018	0 -0.021
DCON Tolerans (mm)	0 -0.008	0 -0.009	0 -0.011	0 -0.013

Sipariş Numarası	DC	(l/d)	OAL	LU	LCF	LH	LF	PL	DCON	DP1021	Tür
MPS1-0300S-DIN	3	3	62	15.0	20	26	61.5	0.5	6	□	3
MPS1-0300S-DIN-C		3	62	15.0	20	26	61.5	0.5	6	●	1
MPS1-0300L-DIN		5	66	20.0	25	30	65.5	0.5	6	□	3
MPS1-0300L-DIN-C		5	66	20.0	25	30	65.5	0.5	6	●	1
MPS1-0300-PC		2	55	6.5	16.5	19.22	55	0.5	6	●	1
MPS1-0300-L8C		8	77	24.6	34	41	76	0.5	6	●	1
MPS1-0300-L10C		10	80	30.5	37.5	43	79	0.5	6	●	1
MPS1-0300-L12C		12	86	36.5	43.5	49	85	0.5	6	●	1
MPS1-0300-L15C		15	95	45.5	52.5	58	94	0.5	6	●	1
MPS1-0300-L20C		20	110	60.5	67.5	73	109	0.5	6	●	1
MPS1-0300-L25C		25	125	75.5	82.5	88	124	0.5	6	●	1
MPS1-0300-L30C		30	140	90.5	97.5	103	139	0.5	6	●	1
MPS1-0300-L35C		35	159	105.5	113.5	122	158	0.5	6	□	1
MPS1-0300-L40C		40	174	120.5	128.5	137	173	0.5	6	●	1

● : Avrupa standart stokta. ★ : Japonya standart stokta. □ : Yalnızca Siparişe Yönelik Üretilmektedir.

# MPS1

## YEKPARE KARBÜR MATKAP

Sipariş Numarası	DC	(l/d)	OAL	LU	LCF	LH	LF	PL	DCON	DP1021	Tür	
MPS1-0305S-DIN	3.05	3	62	15.0	20	26	61.4	0.6	6	□	3	
MPS1-0305S-DIN-C		3	62	15.0	20	26	61.4	0.6	6	●	1	
MPS1-0305L-DIN		5	66	20.0	25	30	65.4	0.6	6	□	3	
MPS1-0305L-DIN-C		5	66	20.0	25	30	65.4	0.6	6	●	1	
MPS1-0310S-DIN	3.1	3	62	14.9	20	26	61.4	0.6	6	□	3	
MPS1-0310S-DIN-C		3	62	14.9	20	26	61.4	0.6	6	●	1	
MPS1-0310L-DIN		5	66	19.9	25	30	65.4	0.6	6	□	3	
MPS1-0310L-DIN-C		5	66	19.9	25	30	65.4	0.6	6	●	1	
MPS1-0310-PC		2	55	6.7	18.5	21.11	55	0.5	6	●	1	
MPS1-0310-L8C		8	83	25.4	40	47	82	0.6	6	●	1	
MPS1-0310-L10C		10	87	31.6	44.6	50	86	0.6	6	□	1	
MPS1-0310-L12C		12	94	37.8	51.6	57	93	0.6	6	●	1	
MPS1-0310-L15C		15	104	47.1	61.6	67	103	0.6	6	●	1	
MPS1-0310-L20C		20	122	62.6	79.6	85	121	0.6	6	●	1	
MPS1-0310-L25C		25	139	78.1	96.6	102	138	0.6	6	●	1	
MPS1-0310-L30C		30	157	93.6	114.6	120	156	0.6	6	●	1	
MPS1-0310-L35C		35	176	109.1	123.6	139	175	0.6	6	□	1	
MPS1-0310-L40C		40	191	124.6	138.6	154	190	0.6	6	●	1	
MPS1-0320S-DIN		3.2	3	62	14.8	20	26	61.4	0.6	6	□	3
MPS1-0320S-DIN-C			3	62	14.8	20	26	61.4	0.6	6	●	1
MPS1-0320L-DIN	5		66	19.8	25	30	65.4	0.6	6	□	3	
MPS1-0320L-DIN-C	5		66	19.8	25	30	65.4	0.6	6	●	1	
MPS1-0320-PC	2		56	6.9	18.5	22	55	0.5	6	●	1	
MPS1-0320-L8C	8		83	26.3	40	47	82	0.6	6	●	1	
MPS1-0320-L10C	10		87	32.6	44.6	50	86	0.6	6	□	1	
MPS1-0320-L12C	12		94	39	51.6	57	93	0.6	6	●	1	
MPS1-0320-L15C	15		104	48.6	61.6	67	103	0.6	6	●	1	
MPS1-0320-L20C	20		122	64.6	79.6	85	121	0.6	6	●	1	
MPS1-0320-L25C	25		139	80.6	96.6	102	138	0.6	6	●	1	
MPS1-0320-L30C	30		157	96.6	114.6	120	156	0.6	6	●	1	
MPS1-0320-L35C	35		176	112.6	123.6	139	175	0.6	6	□	1	
MPS1-0320-L40C	40		191	128.6	138.6	154	190	0.6	6	●	1	
MPS1-0330S-DIN	3.3		3	62	14.7	20	26	61.4	0.6	6	□	3
MPS1-0330S-DIN-C			3	62	14.7	20	26	61.4	0.6	6	●	1
MPS1-0330L-DIN		5	66	20.2	25	30	65.4	0.6	6	□	3	
MPS1-0330L-DIN-C		5	66	20.2	25	30	65.4	0.6	6	●	1	
MPS1-0330-PC		2	56	7.1	18.5	21.9	55	0.5	6	●	1	
MPS1-0330-L8C		8	83	27.1	40	47	82	0.6	6	●	1	
MPS1-0330-L10C		10	87	33.6	44.6	50	86	0.6	6	□	1	
MPS1-0330-L12C		12	94	40.2	51.6	57	93	0.6	6	●	1	
MPS1-0330-L15C		15	104	50.1	61.6	67	103	0.6	6	●	1	
MPS1-0330-L20C		20	122	66.6	79.6	85	121	0.6	6	●	1	
MPS1-0330-L25C		25	139	83.1	96.6	102	138	0.6	6	●	1	
MPS1-0330-L30C		30	157	99.6	114.6	120	156	0.6	6	●	1	
MPS1-0330-L35C		35	176	116.1	132.6	139	175	0.6	6	□	1	
MPS1-0330-L40C		40	191	132.6	148.6	154	190	0.6	6	●	1	

# MPS1

## YEKPARE KARBÜR MATKAP

Sipariş Numarası	DC	(l/d)	OAL	LU	LCF	LH	LF	PL	DCON	DP1021	Tür
MPS1-0340S-DIN	3.4	3	62	14.5	20	26	61.4	0.6	6	□	3
MPS1-0340S-DIN-C		3	62	14.5	20	26	61.4	0.6	6	●	1
MPS1-0340L-DIN		5	66	20.0	25	30	65.4	0.6	6	□	3
MPS1-0340L-DIN-C		5	66	20.0	25	30	65.4	0.6	6	●	1
MPS1-0340-PC		2	56	7.3	18.5	21.79	55	0.5	6	●	1
MPS1-0340-L8C		8	83	27.9	40	47	82	0.6	6	●	1
MPS1-0340-L10C		10	87	34.6	44.6	50	86	0.6	6	□	1
MPS1-0340-L12C		12	94	41.4	51.6	57	93	0.6	6	●	1
MPS1-0340-L15C		15	104	51.6	61.6	67	103	0.6	6	●	1
MPS1-0340-L20C		20	122	68.6	79.6	85	121	0.6	6	●	1
MPS1-0340-L25C		25	139	85.6	96.6	102	138	0.6	6	●	1
MPS1-0340-L30C		30	157	102.6	114.6	120	156	0.6	6	●	1
MPS1-0340-L35C		35	176	119.6	132.6	139	175	0.6	6	□	1
MPS1-0340-L40C		40	191	136.6	148.6	154	190	0.6	6	●	1
MPS1-0350S-DIN	3.5	3	62	14.4	20	26	61.4	0.6	6	□	3
MPS1-0350S-DIN-C		3	62	14.4	20	26	61.4	0.6	6	●	1
MPS1-0350L-DIN		5	66	19.9	25	30	65.4	0.6	6	□	3
MPS1-0350L-DIN-C		5	66	19.9	25	30	65.4	0.6	6	●	1
MPS1-0350-PC		2	56	7.6	18.6	21.68	55	0.6	6	●	1
MPS1-0350-L8C		8	83	28.7	40	47	82	0.6	6	●	1
MPS1-0350-L10C		10	87	35.6	44.6	50	86	0.6	6	□	1
MPS1-0350-L12C		12	94	42.6	51.6	57	93	0.6	6	●	1
MPS1-0350-L15C		15	104	53.1	61.6	67	103	0.6	6	●	1
MPS1-0350-L20C		20	122	70.6	79.6	85	121	0.6	6	●	1
MPS1-0350-L25C		25	139	88.1	96.6	102	138	0.6	6	●	1
MPS1-0350-L30C		30	157	105.6	114.6	120	156	0.6	6	●	1
MPS1-0350-L35C		35	176	123.1	132.6	139	175	0.6	6	□	1
MPS1-0350-L40C		40	191	140.6	148.6	154	190	0.6	6	●	1
MPS1-0360S-DIN	3.6	3	62	14.3	20	26	61.3	0.7	6	□	3
MPS1-0360S-DIN-C		3	62	14.3	20	26	61.3	0.7	6	●	1
MPS1-0360L-DIN		5	66	19.8	25	30	65.3	0.7	6	□	3
MPS1-0360L-DIN-C		5	66	19.8	25	30	65.3	0.7	6	●	1
MPS1-0360-PC		2	56	7.8	20.6	23.57	55	0.6	6	●	1
MPS1-0360-L8C		8	88	29.5	45	51	87	0.7	6	●	1
MPS1-0360-L10C		10	93	36.7	50.7	56	92	0.7	6	□	1
MPS1-0360-L12C		12	101	43.9	58.7	64	100	0.7	6	●	1
MPS1-0360-L15C		15	113	54.7	70.7	76	112	0.7	6	●	1
MPS1-0360-L20C		20	133	72.7	90.7	96	132	0.7	6	●	1
MPS1-0360-L25C		25	153	90.7	110.7	116	152	0.7	6	□	1
MPS1-0360-L30C		30	173	108.7	130.7	136	172	0.7	6	●	1
MPS1-0360-L35C		35	193	126.7	143.7	156	192	0.7	6	□	1
MPS1-0360-L40C		40	213	144.7	160.7	176	212	0.7	6	●	1

# MPS1

## YEKPARE KARBÜR MATKAP

Sipariş Numarası	DC	(l/d)	OAL	LU	LCF	LH	LF	PL	DCON	DP1021	Tür
MPS1-0370S-DIN	3.7	3	62	14.1	20	26	61.3	0.7	6	□	3
MPS1-0370S-DIN-C		3	62	14.1	20	26	61.3	0.7	6	●	1
MPS1-0370L-DIN		5	66	20.1	26	30	65.3	0.7	6	□	3
MPS1-0370L-DIN-C		5	66	20.1	26	30	65.3	0.7	6	●	1
MPS1-0370-PC		2	56	8	20.6	23.47	55	0.6	6	●	1
MPS1-0370-L8C		8	88	30.4	45	51	87	0.7	6	●	1
MPS1-0370-L10C		10	93	37.7	50.7	56	92	0.7	6	□	1
MPS1-0370-L12C		12	101	45.1	58.7	64	100	0.7	6	●	1
MPS1-0370-L15C		15	113	56.2	70.7	76	112	0.7	6	●	1
MPS1-0370-L20C		20	133	74.7	90.7	96	132	0.7	6	●	1
MPS1-0370-L25C		25	153	93.2	110.7	116	152	0.7	6	●	1
MPS1-0370-L30C		30	173	111.7	130.7	136	172	0.7	6	●	1
MPS1-0370-L35C		35	193	130.2	143.7	156	192	0.7	6	□	1
MPS1-0370-L40C		40	213	148.7	160.7	176	212	0.7	6	●	1
MPS1-0380S-DIN	3.8	3	66	18.0	24	30	65.3	0.7	6	□	3
MPS1-0380S-DIN-C		3	66	18.0	24	30	65.3	0.7	6	●	1
MPS1-0380L-DIN		5	74	28.0	34	38	73.3	0.7	6	□	3
MPS1-0380L-DIN-C		5	74	28.0	34	38	73.3	0.7	6	●	1
MPS1-0380-PC		2	56	8.2	20.6	23.36	55	0.6	6	●	1
MPS1-0380-L8C		8	88	31.2	45	51	87	0.7	6	●	1
MPS1-0380-L10C		10	93	38.7	50.7	56	92	0.7	6	□	1
MPS1-0380-L12C		12	101	46.3	58.7	64	100	0.7	6	●	1
MPS1-0380-L15C		15	113	57.7	70.7	76	112	0.7	6	●	1
MPS1-0380-L20C		20	133	76.7	90.7	96	132	0.7	6	●	1
MPS1-0380-L25C		25	153	95.7	110.7	116	152	0.7	6	●	1
MPS1-0380-L30C		30	173	114.7	130.7	136	172	0.7	6	●	1
MPS1-0380-L35C		35	193	133.7	150.7	156	192	0.7	6	□	1
MPS1-0380-L40C		40	213	152.7	170.7	176	212	0.7	6	●	1
MPS1-0390S-DIN	3.9	3	66	17.9	24	30	65.3	0.7	6	□	3
MPS1-0390S-DIN-C		3	66	17.9	24	30	65.3	0.7	6	●	1
MPS1-0390L-DIN		5	74	27.9	34	38	73.3	0.7	6	□	3
MPS1-0390L-DIN-C		5	74	27.9	34	38	73.3	0.7	6	●	1
MPS1-0390-PC		2	56	8.4	20.6	23.25	55	0.6	6	●	1
MPS1-0390-L8C		8	88	32.0	45	51	87	0.7	6	●	1
MPS1-0390-L10C		10	93	39.7	50.7	56	92	0.7	6	□	1
MPS1-0390-L12C		12	101	47.5	58.7	64	100	0.7	6	●	1
MPS1-0390-L15C		15	113	59.2	70.7	76	112	0.7	6	●	1
MPS1-0390-L20C		20	133	78.7	90.7	96	132	0.7	6	●	1
MPS1-0390-L25C		25	153	98.2	110.7	116	152	0.7	6	□	1
MPS1-0390-L30C		30	173	117.7	130.7	136	172	0.7	6	●	1
MPS1-0390-L35C		35	193	137.2	150.7	156	192	0.7	6	□	1
MPS1-0390-L40C		40	213	156.7	170.7	176	212	0.7	6	●	1



# MPS1

## YEKPARE KARBÜR MATKAP

Sipariş Numarası	DC	(l/d)	OAL	LU	LCF	LH	LF	PL	DCON	DP1021	Tür
MPS1-0400S-DIN	4	3	66	17.7	24	30	65.3	0.7	6	□	3
MPS1-0400S-DIN-C		3	66	17.7	24	30	65.3	0.7	6	●	1
MPS1-0400L-DIN		5	74	27.7	34	38	73.3	0.7	6	□	3
MPS1-0400L-DIN-C		5	74	27.7	34	38	73.3	0.7	6	●	1
MPS1-0400-PC		2	56	8.6	20.6	23.14	55	0.6	6	●	1
MPS1-0400-L8C		8	88	32.8	45	51	87	0.7	6	●	1
MPS1-0400-L10C		10	93	40.7	50.7	56	92	0.7	6	●	1
MPS1-0400-L12C		12	101	48.7	58.7	64	100	0.7	6	●	1
MPS1-0400-L15C		15	113	60.7	70.7	76	112	0.7	6	●	1
MPS1-0400-L20C		20	133	80.7	90.7	96	132	0.7	6	●	1
MPS1-0400-L25C		25	153	100.7	110.7	116	152	0.7	6	●	1
MPS1-0400-L30C		30	173	120.7	130.7	136	172	0.7	6	●	1
MPS1-0400-L35C		35	193	140.7	150.7	156	192	0.7	6	□	1
MPS1-0400-L40C		40	213	160.7	170.7	176	212	0.7	6	●	1
MPS1-0405S-DIN	4.05	3	66	17.7	24	30	65.3	0.7	6	□	3
MPS1-0405S-DIN-C		3	66	17.7	24	30	65.3	0.7	6	●	1
MPS1-0405L-DIN		5	74	27.7	34	38	73.3	0.7	6	□	3
MPS1-0405L-DIN-C		5	74	27.7	34	38	73.3	0.7	6	●	1
MPS1-0410S-DIN	4.1	3	66	17.6	24	30	65.3	0.7	6	□	3
MPS1-0410S-DIN-C		3	66	17.6	24	30	65.3	0.7	6	●	1
MPS1-0410L-DIN		5	74	27.6	34	38	73.3	0.7	6	□	3
MPS1-0410L-DIN-C		5	74	27.6	34	38	73.3	0.7	6	●	1
MPS1-0410-PC		2	63	8.8	22.6	25.04	62	0.6	6	●	1
MPS1-0410-L8C		8	93	33.6	51	56	92	0.7	6	●	1
MPS1-0410-L10C		10	100	41.7	58.7	63	99	0.7	6	□	1
MPS1-0410-L12C		12	109	49.9	67.7	72	108	0.7	6	●	1
MPS1-0410-L15C		15	122	62.2	80.7	85	121	0.7	6	●	1
MPS1-0410-L20C		20	145	82.7	103.7	108	144	0.7	6	●	1
MPS1-0410-L25C		25	167	103.2	125.7	130	166	0.7	6	●	1
MPS1-0410-L30C		30	190	123.7	148.7	153	189	0.7	6	●	1
MPS1-0410-L35C		35	212	144.2	164.7	175	211	0.7	6	□	1
MPS1-0410-L40C		40	236	164.7	184.7	199	235	0.7	6	●	1
MPS1-0420S-DIN	4.2	3	66	17.5	24	30	65.2	0.8	6	□	3
MPS1-0420S-DIN-C		3	66	17.5	24	30	65.2	0.8	6	●	1
MPS1-0420L-DIN		5	74	28.0	34	38	73.2	0.8	6	□	3
MPS1-0420L-DIN-C		5	74	28.0	34	38	73.2	0.8	6	●	1
MPS1-0420-PC		2	63	9.1	22.7	24.93	62	0.7	6	●	1
MPS1-0420-L8C		8	93	34.5	51	56	92	0.8	6	●	1
MPS1-0420-L10C		10	100	42.8	58.8	63	99	0.8	6	□	1
MPS1-0420-L12C		12	109	51.2	67.8	72	108	0.8	6	●	1
MPS1-0420-L15C		15	122	63.8	80.8	85	121	0.8	6	●	1
MPS1-0420-L20C		20	145	84.8	103.8	108	144	0.8	6	●	1
MPS1-0420-L25C		25	167	105.8	125.8	130	166	0.8	6	●	1
MPS1-0420-L30C		30	190	126.8	148.8	153	189	0.8	6	●	1
MPS1-0420-L35C		35	212	147.8	164.8	175	211	0.8	6	●	1
MPS1-0420-L40C		40	236	168.8	184.8	199	235	0.8	6	●	1

# MPS1

## YEKPARE KARBÜR MATKAP

Sipariş Numarası	DC	(l/d)	OAL	LU	LCF	LH	LF	PL	DCON	DP1021	Tür
MPS1-0430S-DIN	4.3	3	66	17.3	24	30	65.2	0.8	6	□	3
MPS1-0430S-DIN-C		3	66	17.3	24	30	65.2	0.8	6	●	1
MPS1-0430L-DIN		5	74	27.8	34	38	73.2	0.8	6	□	3
MPS1-0430L-DIN-C		5	74	27.8	34	38	73.2	0.8	6	●	1
MPS1-0430-PC		2	63	9.3	22.7	24.82	62	0.7	6	●	1
MPS1-0430-L8C		8	93	35.3	51	56	92	0.8	6	●	1
MPS1-0430-L10C		10	100	43.8	58.8	63	99	0.8	6	□	1
MPS1-0430-L12C		12	109	52.4	67.8	72	108	0.8	6	●	1
MPS1-0430-L15C		15	122	65.3	80.8	85	121	0.8	6	●	1
MPS1-0430-L20C		20	145	86.8	103.8	108	144	0.8	6	●	1
MPS1-0430-L25C		25	167	108.3	125.8	130	166	0.8	6	●	1
MPS1-0430-L30C		30	190	129.8	148.8	153	189	0.8	6	●	1
MPS1-0430-L35C		35	212	151.3	170.8	175	211	0.8	6	□	1
MPS1-0430-L40C		40	236	172.8	194.8	199	235	0.8	6	●	1
MPS1-0440S-DIN	4.4	3	66	17.2	24	30	65.2	0.8	6	□	3
MPS1-0440S-DIN-C		3	66	17.2	24	30	65.2	0.8	6	●	1
MPS1-0440L-DIN		5	74	27.7	34	38	73.2	0.8	6	□	3
MPS1-0440L-DIN-C		5	74	27.7	34	38	73.2	0.8	6	●	1
MPS1-0440-PC		2	63	9.5	22.7	24.72	62	0.7	6	●	1
MPS1-0440-L8C		8	93	36.1	51	56	92	0.8	6	●	1
MPS1-0440-L10C		10	100	44.8	58.8	63	99	0.8	6	□	1
MPS1-0440-L12C		12	109	53.6	67.8	72	108	0.8	6	●	1
MPS1-0440-L15C		15	122	66.8	80.8	85	121	0.8	6	●	1
MPS1-0440-L20C		20	145	88.8	103.8	108	144	0.8	6	□	1
MPS1-0440-L25C		25	167	110.8	125.8	130	166	0.8	6	□	1
MPS1-0440-L30C		30	190	132.8	148.8	153	189	0.8	6	□	1
MPS1-0440-L35C		35	212	154.8	170.8	175	211	0.8	6	□	1
MPS1-0440-L40C		40	236	176.8	194.8	199	235	0.8	6	●	1
MPS1-0450S-DIN	4.5	3	66	17.1	24	30	65.2	0.8	6	□	3
MPS1-0450S-DIN-C		3	66	17.1	24	30	65.2	0.8	6	●	1
MPS1-0450L-DIN		5	74	27.6	34	38	73.2	0.8	6	□	3
MPS1-0450L-DIN-C		5	74	27.6	34	38	73.2	0.8	6	●	1
MPS1-0450-PC		2	63	9.7	22.7	24.61	62	0.7	6	●	1
MPS1-0450-L8C		8	93	36.9	51	56	92	0.8	6	●	1
MPS1-0450-L10C		10	100	45.8	58.8	63	99	0.8	6	□	1
MPS1-0450-L12C		12	109	54.8	67.8	72	108	0.8	6	●	1
MPS1-0450-L15C		15	122	68.3	80.8	85	121	0.8	6	●	1
MPS1-0450-L20C		20	145	90.8	103.8	108	144	0.8	6	●	1
MPS1-0450-L25C		25	167	113.3	125.8	130	166	0.8	6	●	1
MPS1-0450-L30C		30	190	135.8	148.8	153	189	0.8	6	●	1
MPS1-0450-L35C		35	212	158.3	170.8	175	211	0.8	6	□	1
MPS1-0450-L40C		40	236	180.8	194.8	199	235	0.8	6	●	1

# MPS1

## YEKPARE KARBÜR MATKAP

Sipariş Numarası	DC	(l/d)	OAL	LU	LCF	LH	LF	PL	DCON	DP1021	Tür
MPS1-0460S-DIN	4.6	3	66	16.9	24	30	65.2	0.8	6	□	4
MPS1-0460S-DIN-C		3	66	16.9	24	30	65.2	0.8	6	●	2
MPS1-0460L-DIN		5	74	28.9	36	38	73.2	0.8	6	□	4
MPS1-0460L-DIN-C		5	74	28.9	36	38	73.2	0.8	6	●	2
MPS1-0460-PC		2	63	9.9	24.7	28	62	0.7	6	●	2
MPS1-0460-L8C		8	96	37.8	55	59	95	0.8	6	●	2
MPS1-0460-L10C		10	106	46.8	65.8	69	105	0.8	6	□	2
MPS1-0460-L12C		12	116	56	75.8	79	115	0.8	6	●	2
MPS1-0460-L15C		15	131	69.8	90.8	94	130	0.8	6	●	2
MPS1-0460-L20C		20	156	92.8	115.8	119	155	0.8	6	●	2
MPS1-0460-L25C		25	181	115.8	140.8	144	180	0.8	6	●	2
MPS1-0460-L30C		30	206	138.8	165.8	169	205	0.8	6	●	2
MPS1-0460-L35C		35	230	161.8	184.8	193	229	0.8	6	□	2
MPS1-0460-L40C		40	255	184.8	204.8	218	254	0.8	6	●	2
MPS1-0465S-DIN	4.65	3	66	16.9	24	30	65.2	0.8	6	□	4
MPS1-0465S-DIN-C		3	66	16.9	24	30	65.2	0.8	6	●	2
MPS1-0465L-DIN		5	74	28.9	36	38	73.2	0.8	6	□	4
MPS1-0465L-DIN-C		5	74	28.9	36	38	73.2	0.8	6	●	2
MPS1-0470S-DIN	4.7	3	66	16.8	24	30	65.1	0.9	6	□	4
MPS1-0470S-DIN-C		3	66	16.8	24	30	65.1	0.9	6	●	2
MPS1-0470L-DIN		5	74	28.8	36	38	73.1	0.9	6	□	4
MPS1-0470L-DIN-C		5	74	28.8	36	38	73.1	0.9	6	●	2
MPS1-0470-PC		2	63	10.1	24.7	28	62	0.7	6	●	2
MPS1-0470-L8C		8	96	38.6	55	59	95	0.9	6	●	2
MPS1-0470-L10C		10	106	47.9	65.9	69	105	0.9	6	□	2
MPS1-0470-L12C		12	116	57.3	75.9	79	115	0.9	6	●	2
MPS1-0470-L15C		15	131	71.4	90.9	94	130	0.9	6	●	2
MPS1-0470-L20C		20	156	94.9	115.9	119	155	0.9	6	●	2
MPS1-0470-L25C		25	181	118.4	140.9	144	180	0.9	6	●	2
MPS1-0470-L30C		30	206	141.9	165.9	169	205	0.9	6	●	2
MPS1-0470-L35C		35	230	165.4	184.9	193	229	0.9	6	□	2
MPS1-0470-L40C		40	255	188.9	204.9	218	254	0.9	6	●	2
MPS1-0480S-DIN	4.8	3	66	20.7	28	30	65.1	0.9	6	□	4
MPS1-0480S-DIN-C		3	66	20.7	28	30	65.1	0.9	6	●	2
MPS1-0480L-DIN		5	82	36.7	44	46	81.1	0.9	6	□	4
MPS1-0480L-DIN-C		5	82	36.7	44	46	81.1	0.9	6	●	2
MPS1-0480-PC		2	63	10.4	24.8	28	62	0.8	6	●	2
MPS1-0480-L8C		8	96	39.4	55	59	95	0.9	6	●	2
MPS1-0480-L10C		10	106	48.9	65.9	69	105	0.9	6	□	2
MPS1-0480-L12C		12	116	58.5	75.9	79	115	0.9	6	●	2
MPS1-0480-L15C		15	131	72.9	90.9	94	130	0.9	6	●	2
MPS1-0480-L20C		20	156	96.9	115.9	119	155	0.9	6	●	2
MPS1-0480-L25C		25	181	120.9	140.9	144	180	0.9	6	●	2
MPS1-0480-L30C		30	206	144.9	165.9	169	205	0.9	6	●	2
MPS1-0480-L35C		35	230	168.9	190.9	193	229	0.9	6	□	2
MPS1-0480-L40C		40	255	192.9	215.9	218	254	0.9	6	●	2

# MPS1

## YEKPARE KARBÜR MATKAP

Sipariş Numarası	DC	(l/d)	OAL	LU	LCF	LH	LF	PL	DCON	DP1021	Tür	
MPS1-0490S-DIN	4.9	3	66	20.5	28	30	65.1	0.9	6	□	4	
MPS1-0490S-DIN-C		3	66	20.5	28	30	65.1	0.9	6	●	2	
MPS1-0490L-DIN		5	82	36.5	44	46	81.1	0.9	6	□	4	
MPS1-0490L-DIN-C		5	82	36.5	44	46	81.1	0.9	6	●	2	
MPS1-0490-PC		2	63	10.6	24.8	28	62	0.8	6	●	2	
MPS1-0490-L8C		8	96	40.2	55	59	95	0.9	6	●	2	
MPS1-0490-L10C		10	106	49.9	65.9	69	105	0.9	6	□	2	
MPS1-0490-L12C		12	116	59.7	75.9	79	115	0.9	6	●	2	
MPS1-0490-L15C		15	131	74.4	90.9	94	130	0.9	6	●	2	
MPS1-0490-L20C		20	156	98.9	115.9	119	155	0.9	6	□	2	
MPS1-0490-L25C		25	181	123.4	140.9	144	180	0.9	6	●	2	
MPS1-0490-L30C		30	206	147.9	165.9	169	205	0.9	6	●	2	
MPS1-0490-L35C		35	230	172.4	190.9	193	229	0.9	6	□	2	
MPS1-0490-L40C		40	255	196.9	215.9	218	254	0.9	6	●	2	
MPS1-0500S-DIN	5	3	66	20.4	28	30	65.1	0.9	6	□	4	
MPS1-0500S-DIN-C		3	66	20.4	28	30	65.1	0.9	6	●	2	
MPS1-0500L-DIN		5	82	36.4	44	46	81.1	0.9	6	□	4	
MPS1-0500L-DIN-C		5	82	36.4	44	46	81.1	0.9	6	●	2	
MPS1-0500-PC		2	63	10.8	24.8	26	62	0.8	6	●	2	
MPS1-0500-L8C		8	96	41.0	55	59	95	0.9	6	●	2	
MPS1-0500-L10C		10	106	50.9	65.9	69	105	0.9	6	●	2	
MPS1-0500-L12C		12	116	60.9	75.9	79	115	0.9	6	●	2	
MPS1-0500-L15C		15	131	75.9	90.9	94	130	0.9	6	●	2	
MPS1-0500-L20C		20	156	100.9	115.9	119	155	0.9	6	●	2	
MPS1-0500-L25C		25	181	125.9	140.9	144	180	0.9	6	●	2	
MPS1-0500-L30C		30	206	150.9	165.9	169	205	0.9	6	●	2	
MPS1-0500-L35C		35	230	175.9	190.9	193	229	0.9	6	□	2	
MPS1-0500-L40C		40	255	200.9	215.9	218	254	0.9	6	●	2	
MPS1-0505S-DIN	5.05	3	66	20.3	28	30	65.1	0.9	6	□	4	
MPS1-0505S-DIN-C		3	66	20.3	28	30	65.1	0.9	6	●	2	
MPS1-0505L-DIN		5	82	36.3	44	46	81.1	0.9	6	□	4	
MPS1-0505L-DIN-C		5	82	36.3	44	46	81.1	0.9	6	●	2	
MPS1-0510S-DIN		5.1	3	66	20.3	28	30	65.1	0.9	6	□	4
MPS1-0510S-DIN-C			3	66	20.3	28	30	65.1	0.9	6	●	2
MPS1-0510L-DIN			5	82	36.3	44	46	81.1	0.9	6	□	4
MPS1-0510L-DIN-C			5	82	36.3	44	46	81.1	0.9	6	●	2
MPS1-0510-PC			2	67	11	26.8	29	66	0.8	6	●	2
MPS1-0510-L8C			8	102	41.9	62	65	101	0.9	6	●	2
MPS1-0510-L10C			10	113	51.9	72.9	76	112	0.9	6	□	2
MPS1-0510-L12C			12	124	62.1	83.9	87	123	0.9	6	●	2
MPS1-0510-L15C			15	140	77.4	99.9	103	139	0.9	6	●	2
MPS1-0510-L20C			20	168	102.9	127.9	131	167	0.9	6	●	2
MPS1-0510-L25C	25		195	128.4	154.9	158	194	0.9	6	●	2	
MPS1-0510-L30C	30		223	153.9	182.9	186	222	0.9	6	●	2	
MPS1-0510-L35C	35		249	179.4	203.9	212	248	0.9	6	□	2	
MPS1-0510-L40C	40		279	204.9	230.9	242	278	0.9	6	●	2	

# MPS1

## YEKPARE KARBÜR MATKAP

Sipariş Numarası	DC	(l/d)	OAL	LU	LCF	LH	LF	PL	DCON	DP1021	Tür
MPS1-0520S-DIN	5.2	3	66	20.1	28	30	65.1	0.9	6	□	4
MPS1-0520S-DIN-C		3	66	20.1	28	30	65.1	0.9	6	●	2
MPS1-0520L-DIN		5	82	36.1	44	46	81.1	0.9	6	□	4
MPS1-0520L-DIN-C		5	82	36.1	44	46	81.1	0.9	6	●	2
MPS1-0520-PC		2	67	11.2	26.8	29	66	0.8	6	●	2
MPS1-0520-L8C		8	102	42.7	62	65	101	0.9	6	●	2
MPS1-0520-L10C		10	113	52.9	72.9	76	112	0.9	6	□	2
MPS1-0520-L12C		12	124	63.3	83.9	87	123	0.9	6	●	2
MPS1-0520-L15C		15	140	78.9	99.9	103	139	0.9	6	●	2
MPS1-0520-L20C		20	168	104.9	127.9	131	167	0.9	6	●	2
MPS1-0520-L25C		25	195	130.9	154.9	158	194	0.9	6	●	2
MPS1-0520-L30C		30	223	156.9	182.9	186	222	0.9	6	●	2
MPS1-0520-L35C		35	249	182.9	203.9	212	248	0.9	6	□	2
MPS1-0520-L40C		40	279	208.9	230.9	242	278	0.9	6	●	2
MPS1-0530S-DIN	5.3	3	66	20.0	28	30	65	1.0	6	□	4
MPS1-0530S-DIN-C		3	66	20.0	28	30	65	1.0	6	●	2
MPS1-0530L-DIN		5	82	36.0	44	46	81	1.0	6	□	4
MPS1-0530L-DIN-C		5	82	36.0	44	46	81	1.0	6	●	2
MPS1-0530-PC		2	67	11.4	26.8	29	66	0.8	6	●	2
MPS1-0530-L8C		8	102	43.5	62	65	101	1.0	6	●	2
MPS1-0530-L10C		10	113	54	73	76	112	1.0	6	□	2
MPS1-0530-L12C		12	124	64.6	84	87	123	1.0	6	●	2
MPS1-0530-L15C		15	140	80.5	100	103	139	1.0	6	●	2
MPS1-0530-L20C		20	168	107	128	131	167	1.0	6	□	2
MPS1-0530-L25C		25	195	133.5	155	158	194	1.0	6	●	2
MPS1-0530-L30C		30	223	160	183	186	222	1.0	6	●	2
MPS1-0530-L35C		35	249	186.5	210	212	248	1.0	6	□	2
MPS1-0530-L40C		40	279	213	241	242	278	1.0	6	●	2
MPS1-0540S-DIN-C	5.4	3	66	19.9	28	30	65	1.0	6	●	2
MPS1-0540S-DIN		3	66	19.9	28	30	65	1.0	6	□	4
MPS1-0540L-DIN		5	82	35.9	44	46	81	1.0	6	□	4
MPS1-0540L-DIN-C		5	82	35.9	44	46	81	1.0	6	●	2
MPS1-0540-PC		2	67	11.7	26.9	29	66	0.9	6	●	2
MPS1-0540-L8C		8	102	44.3	62	65	101	1.0	6	●	2
MPS1-0540-L10C		10	113	55	73	76	112	1.0	6	□	2
MPS1-0540-L12C		12	124	65.8	84	87	123	1.0	6	●	2
MPS1-0540-L15C		15	140	82	100	103	139	1.0	6	●	2
MPS1-0540-L20C		20	168	109	128	131	167	1.0	6	●	2
MPS1-0540-L25C		25	195	136	155	158	194	1.0	6	□	2
MPS1-0540-L30C		30	223	163	183	186	222	1.0	6	□	2
MPS1-0540-L35C		35	249	190	210	212	248	1.0	6	□	2
MPS1-0540-L40C		40	279	217	241	242	278	1.0	6	●	2

# MPS1

## YEKPARE KARBÜR MATKAP

Sipariş Numarası	DC	(l/d)	OAL	LU	LCF	LH	LF	PL	DCON	DP1021	Tür
MPS1-0550S-DIN	5.5	3	66	19.8	28	30	65	1.0	6	□	4
MPS1-0550S-DIN-C		3	66	19.8	28	30	65	1.0	6	●	2
MPS1-0550L-DIN		5	82	35.8	44	46	81	1.0	6	□	4
MPS1-0550L-DIN-C		5	82	35.8	44	46	81	1.0	6	●	2
MPS1-0550-PC		2	67	11.9	26.9	29	66	0.9	6	●	2
MPS1-0550-L8C		8	102	45.1	62	65	101	1.0	6	●	2
MPS1-0550-L10C		10	113	56	73	76	112	1.0	6	□	2
MPS1-0550-L12C		12	124	67	84	87	123	1.0	6	●	2
MPS1-0550-L15C		15	140	83.5	100	103	139	1.0	6	●	2
MPS1-0550-L20C		20	168	111	128	131	167	1.0	6	●	2
MPS1-0550-L25C		25	195	138.5	155	158	194	1.0	6	●	2
MPS1-0550-L30C		30	223	166	183	186	222	1.0	6	●	2
MPS1-0550-L35C		35	249	193.5	210	212	248	1.0	6	□	2
MPS1-0550-L40C		40	279	221	241	242	278	1.0	6	●	2
MPS1-0555S-DIN	5.55	3	66	19.7	28	30	65	1.0	6	□	4
MPS1-0555S-DIN-C		3	66	19.7	28	30	65	1.0	6	●	2
MPS1-0555L-DIN		5	82	35.7	44	46	81	1.0	6	□	4
MPS1-0555L-DIN-C		5	82	35.7	44	46	81	1.0	6	●	2
MPS1-0560S-DIN	5.6	3	66	19.6	28	30	65	1.0	6	□	4
MPS1-0560S-DIN-C		3	66	19.6	28	30	65	1.0	6	●	2
MPS1-0560L-DIN		5	82	35.6	44	46	81	1.0	6	□	4
MPS1-0560L-DIN-C		5	82	35.6	44	46	81	1.0	6	●	2
MPS1-0560-PC		2	67	12.1	28.9	29	66	0.9	6	●	2
MPS1-0560-L8C		8	107	46.0	67	70	106	1.0	6	●	2
MPS1-0560-L10C		10	119	57	79	82	118	1.0	6	□	2
MPS1-0560-L12C		12	131	68.2	91	94	130	1.0	6	●	2
MPS1-0560-L15C		15	149	85	109	112	148	1.0	6	●	2
MPS1-0560-L20C		20	179	113	139	142	178	1.0	6	□	2
MPS1-0560-L25C		25	209	141	169	172	208	1.0	6	□	2
MPS1-0560-L30C		30	239	169	199	202	238	1.0	6	●	2
MPS1-0560-L35C		35	268	197	223	231	267	1.0	6	□	2
MPS1-0560-L40C		40	299	225	251	262	298	1.0	6	●	2
MPS1-0570S-DIN	5.7	3	66	19.5	28	30	65	1.0	6	□	4
MPS1-0570S-DIN-C		3	66	19.5	28	30	65	1.0	6	●	2
MPS1-0570L-DIN		5	82	35.5	44	46	81	1.0	6	□	4
MPS1-0570L-DIN-C		5	82	35.5	44	46	81	1.0	6	●	2
MPS1-0570-PC		2	67	12.3	28.9	29	66	0.9	6	●	2
MPS1-0570-L8C		8	107	46.8	67	70	106	1.0	6	●	2
MPS1-0570-L10C		10	119	58	79	82	118	1.0	6	□	2
MPS1-0570-L12C		12	131	69.4	91	94	130	1.0	6	●	2
MPS1-0570-L15C		15	149	86.5	109	112	148	1.0	6	●	2
MPS1-0570-L20C		20	179	115	139	142	178	1.0	6	□	2
MPS1-0570-L25C		25	209	143.5	169	172	208	1.0	6	●	2
MPS1-0570-L30C		30	239	172	199	202	238	1.0	6	□	2
MPS1-0570-L35C		35	268	200.5	223	231	267	1.0	6	□	2
MPS1-0570-L40C		40	299	229	251	262	298	1.0	6	●	2

# MPS1

## YEKPARE KARBÜR MATKAP

Sipariş Numarası	DC	(l/d)	OAL	LU	LCF	LH	LF	PL	DCON	DP1021	Tür
MPS1-0580S-DIN	5.8	3	66	19.4	28	30	64.9	1.1	6	□	4
MPS1-0580S-DIN-C		3	66	19.4	28	30	64.9	1.1	6	●	2
MPS1-0580L-DIN		5	82	35.4	44	46	80.9	1.1	6	□	4
MPS1-0580L-DIN-C		5	82	35.4	44	46	80.9	1.1	6	●	2
MPS1-0580-PC		2	67	12.5	28.9	29	66	0.9	6	●	2
MPS1-0580-L8C		8	107	47.6	67	70	106	1.1	6	●	2
MPS1-0580-L10C		10	119	59.1	79.1	82	118	1.1	6	□	2
MPS1-0580-L12C		12	131	70.7	91.1	94	130	1.1	6	●	2
MPS1-0580-L15C		15	149	88.1	109.1	112	148	1.1	6	●	2
MPS1-0580-L20C		20	179	117.1	139.1	142	178	1.1	6	●	2
MPS1-0580-L25C		25	209	146.1	169.1	172	208	1.1	6	□	2
MPS1-0580-L30C		30	239	175.1	199.1	202	238	1.1	6	●	2
MPS1-0580-L35C		35	268	204.1	229.1	231	267	1.1	6	□	2
MPS1-0580-L40C		40	299	233.1	261.1	262	298	1.1	6	●	2
MPS1-0590S-DIN	5.9	3	66	19.2	28	30	64.9	1.1	6	□	4
MPS1-0590S-DIN-C		3	66	19.2	28	30	64.9	1.1	6	●	2
MPS1-0590L-DIN		5	82	35.2	44	46	80.9	1.1	6	□	4
MPS1-0590L-DIN-C		5	82	35.2	44	46	80.9	1.1	6	●	2
MPS1-0590-PC		2	67	12.7	28.9	29	66	0.9	6	●	2
MPS1-0590-L8C		8	107	48.4	67	70	106	1.1	6	●	2
MPS1-0590-L10C		10	119	60.1	79.1	82	118	1.1	6	□	2
MPS1-0590-L12C		12	131	71.9	91.1	94	130	1.1	6	●	2
MPS1-0590-L15C		15	149	89.6	109.1	112	148	1.1	6	●	2
MPS1-0590-L20C		20	179	119.1	139.1	142	178	1.1	6	●	2
MPS1-0590-L25C		25	209	148.6	169.1	172	208	1.1	6	●	2
MPS1-0590-L30C		30	239	178.1	199.1	202	238	1.1	6	□	2
MPS1-0590-L35C		35	268	207.6	229.1	231	267	1.1	6	□	2
MPS1-0590-L40C		40	299	237.1	261.1	262	298	1.1	6	●	2
MPS1-0600S-DIN	6	3	66	19.1	28	30	64.9	1.1	6	□	4
MPS1-0600S-DIN-C		3	66	19.1	28	30	64.9	1.1	6	●	2
MPS1-0600L-DIN		5	82	35.1	44	46	80.9	1.1	6	□	4
MPS1-0600L-DIN-C		5	82	35.1	44	46	80.9	1.1	6	●	2
MPS1-0600-PC		2	67	12.9	28.9	29	66	0.9	6	●	2
MPS1-0600-L8C		8	107	49.2	67	70	106	1.1	6	●	2
MPS1-0600-L10C		10	119	61.1	79.1	82	118	1.1	6	●	2
MPS1-0600-L12C		12	131	73.1	91.1	94	130	1.1	6	●	2
MPS1-0600-L15C		15	149	91.1	109.1	112	148	1.1	6	●	2
MPS1-0600-L20C		20	179	121.1	139.1	142	178	1.1	6	●	2
MPS1-0600-L25C		25	209	151.1	169.1	172	208	1.1	6	●	2
MPS1-0600-L30C		30	239	181.1	199.1	202	238	1.1	6	●	2
MPS1-0600-L35C		35	268	211.1	229.1	231	267	1.1	6	□	2
MPS1-0600-L40C		40	299	241.1	261.1	262	298	1.1	6	●	2
MPS1-0605S-DIN	6.05	3	79	25.0	34	43	77.9	1.1	8	□	4
MPS1-0605S-DIN-C		3	79	25.0	34	43	77.9	1.1	8	●	2
MPS1-0605L-DIN		5	91	44.0	53	55	89.9	1.1	8	□	4
MPS1-0605L-DIN-C		5	91	44.0	53	55	89.9	1.1	8	●	2

# MPS1

## YEKPARE KARBÜR MATKAP

Sipariş Numarası	DC	(l/d)	OAL	LU	LCF	LH	LF	PL	DCON	DP1021	Tür
MPS1-0610S-DIN	6.1	3	79	25.0	34	43	77.9	1.1	8	□	4
MPS1-0610S-DIN-C		3	79	25.0	34	43	77.9	1.1	8	●	2
MPS1-0610L-DIN		5	91	44.0	53	55	89.9	1.1	8	□	4
MPS1-0610L-DIN-C		5	91	44.0	53	55	89.9	1.1	8	●	2
MPS1-0610-PC		2	75	13.2	32	35	74	1.0	8	●	2
MPS1-0610-L8C		8	113	50.1	73	76	112	1.1	8	●	2
MPS1-0610-L10C		10	126	62.1	86.1	89	125	1.1	8	□	2
MPS1-0610-L12C		12	139	74.3	99.1	102	138	1.1	8	●	2
MPS1-0610-L15C		15	158	92.6	118.1	121	157	1.1	8	●	2
MPS1-0610-L20C		20	191	123.1	151.1	154	190	1.1	8	●	2
MPS1-0610-L25C		25	223	153.6	183.1	186	222	1.1	8	●	2
MPS1-0610-L30C		30	256	184.1	216.1	219	255	1.1	8	●	2
MPS1-0610-L35C		35	287	214.6	241.1	250	286	1.1	8	□	2
MPS1-0610-L40C		40	321	245.1	271.1	284	320	1.1	8	●	2
MPS1-0620S-DIN		6.2	3	79	24.8	34	43	77.9	1.1	8	□
MPS1-0620S-DIN-C	3		79	24.8	34	43	77.9	1.1	8	●	2
MPS1-0620L-DIN	5		91	43.8	53	55	89.9	1.1	8	□	4
MPS1-0620L-DIN-C	5		91	43.8	53	55	89.9	1.1	8	●	2
MPS1-0620-PC	2		75	13.4	32	35	74	1.0	8	●	2
MPS1-0620-L8C	8		113	50.9	73	76	112	1.1	8	●	2
MPS1-0620-L10C	10		126	63.1	86.1	89	125	1.1	8	□	2
MPS1-0620-L12C	12		139	75.5	99.1	102	138	1.1	8	●	2
MPS1-0620-L15C	15		158	94.1	118.1	121	157	1.1	8	●	2
MPS1-0620-L20C	20		191	125.1	151.1	154	190	1.1	8	●	2
MPS1-0620-L25C	25		223	156.1	183.1	186	222	1.1	8	□	2
MPS1-0620-L30C	30		256	187.1	216.1	219	255	1.1	8	●	2
MPS1-0620-L35C	35		287	218.1	241.1	250	286	1.1	8	□	2
MPS1-0620-L40C	40		321	249.1	271.1	284	320	1.1	8	●	2
MPS1-0630S-DIN	6.3		3	79	24.7	34	43	77.9	1.1	8	□
MPS1-0630S-DIN-C		3	79	24.7	34	43	77.9	1.1	8	●	2
MPS1-0630L-DIN		5	91	43.7	53	55	89.9	1.1	8	□	4
MPS1-0630L-DIN-C		5	91	43.7	53	55	89.9	1.1	8	●	2
MPS1-0630-PC		2	75	13.6	32	35	74	1.0	8	●	2
MPS1-0630-L8C		8	113	51.7	73	76	112	1.1	8	●	2
MPS1-0630-L10C		10	126	64.1	86.1	89	125	1.1	8	□	2
MPS1-0630-L12C		12	139	76.7	99.1	102	138	1.1	8	●	2
MPS1-0630-L15C		15	158	95.6	118.1	121	157	1.1	8	●	2
MPS1-0630-L20C		20	191	127.1	151.1	154	190	1.1	8	●	2
MPS1-0630-L25C		25	223	158.6	183.1	186	222	1.1	8	□	2
MPS1-0630-L30C		30	256	190.1	216.1	219	255	1.1	8	●	2
MPS1-0630-L35C		35	287	221.6	248.1	250	286	1.1	8	□	2
MPS1-0630-L40C		40	321	253.1	281.1	284	320	1.1	8	●	2



# MPS1

## YEKPARE KARBÜR MATKAP

Sipariş Numarası	DC	(l/d)	OAL	LU	LCF	LH	LF	PL	DCON	DP1021	Tür
MPS1-0640S-DIN	6.4	3	79	24.6	34	43	77.8	1.2	8	□	4
MPS1-0640S-DIN-C		3	79	24.6	34	43	77.8	1.2	8	●	2
MPS1-0640L-DIN		5	91	43.6	53	55	89.8	1.2	8	□	4
MPS1-0640L-DIN-C		5	91	43.6	53	55	89.8	1.2	8	●	2
MPS1-0640-PC		2	75	13.8	32	35	74	1.0	8	●	2
MPS1-0640-L8C		8	113	52.5	73	76	112	1.2	8	●	2
MPS1-0640-L10C		10	126	65.2	86.2	89	125	1.2	8	□	2
MPS1-0640-L12C		12	139	78	99.2	102	138	1.2	8	●	2
MPS1-0640-L15C		15	158	97.2	118.2	121	157	1.2	8	●	2
MPS1-0640-L20C		20	191	129.2	151.2	154	190	1.2	8	●	2
MPS1-0640-L25C		25	223	161.2	183.2	186	222	1.2	8	●	2
MPS1-0640-L30C		30	256	193.2	216.2	219	255	1.2	8	●	2
MPS1-0640-L35C		35	287	225.2	248.2	250	286	1.2	8	□	2
MPS1-0640-L40C		40	321	257.2	281.2	284	320	1.2	8	●	2
MPS1-0650S-DIN	6.5	3	79	24.4	34	43	77.8	1.2	8	□	4
MPS1-0650S-DIN-C		3	79	24.4	34	43	77.8	1.2	8	●	2
MPS1-0650L-DIN		5	91	43.4	53	55	89.8	1.2	8	□	4
MPS1-0650L-DIN-C		5	91	43.4	53	55	89.8	1.2	8	●	2
MPS1-0650-PC		2	75	14	32	35	74	1.0	8	●	2
MPS1-0650-L8C		8	113	53.3	73	76	112	1.2	8	●	2
MPS1-0650-L10C		10	126	66.2	86.2	89	125	1.2	8	□	2
MPS1-0650-L12C		12	139	79.2	99.2	102	138	1.2	8	●	2
MPS1-0650-L15C		15	158	98.7	118.2	121	157	1.2	8	●	2
MPS1-0650-L20C		20	191	131.2	151.2	154	190	1.2	8	●	2
MPS1-0650-L25C		25	223	163.7	183.2	186	222	1.2	8	●	2
MPS1-0650-L30C		30	256	196.2	216.2	219	255	1.2	8	●	2
MPS1-0650-L35C		35	287	228.7	248.2	250	286	1.2	8	□	2
MPS1-0650-L40C		40	321	261.2	281.2	284	320	1.2	8	●	2
MPS1-0660S-DIN	6.6	3	79	24.3	34	43	77.8	1.2	8	□	4
MPS1-0660S-DIN-C		3	79	24.3	34	43	77.8	1.2	8	●	2
MPS1-0660L-DIN		5	91	43.3	53	55	89.8	1.2	8	□	4
MPS1-0660L-DIN-C		5	91	43.3	53	55	89.8	1.2	8	●	2
MPS1-0660-PC		2	75	14.2	35	37	74	1.0	8	●	2
MPS1-0660-L8C		8	118	54.2	78	81	117	1.2	8	●	2
MPS1-0660-L10C		10	132	67.2	92.2	95	131	1.2	8	□	2
MPS1-0660-L12C		12	146	80.4	106.2	109	145	1.2	8	●	2
MPS1-0660-L15C		15	167	100.2	127.2	130	166	1.2	8	●	2
MPS1-0660-L20C		20	202	133.2	162.2	165	201	1.2	8	□	2
MPS1-0660-L25C		25	237	166.2	197.2	200	236	1.2	8	●	2
MPS1-0660-L30C		30	272	199.2	232.2	235	271	1.2	8	●	2
MPS1-0660-L35C		35	306	232.2	267.2	269	305	1.2	8	□	2
MPS1-0660-L40C		40	341	265.2	301.2	304	340	1.2	8	●	2

# MPS1

## YEKPARE KARBÜR MATKAP

Sipariş Numarası	DC	(l/d)	OAL	LU	LCF	LH	LF	PL	DCON	DP1021	Tür
MPS1-0670S-DIN	6.7	3	79	24.2	34	43	77.8	1.2	8	□	4
MPS1-0670S-DIN-C		3	79	24.2	34	43	77.8	1.2	8	●	2
MPS1-0670L-DIN		5	91	43.2	53	55	89.8	1.2	8	□	4
MPS1-0670L-DIN-C		5	91	43.2	53	55	89.8	1.2	8	●	2
MPS1-0670-PC		2	75	14.5	35.1	37	74	1.1	8	●	2
MPS1-0670-L8C		8	118	55.0	78	81	117	1.2	8	●	2
MPS1-0670-L10C		10	132	68.2	92.2	95	131	1.2	8	□	2
MPS1-0670-L12C		12	146	81.6	106.2	109	145	1.2	8	●	2
MPS1-0670-L15C		15	167	101.7	127.2	130	166	1.2	8	●	2
MPS1-0670-L20C		20	202	135.2	162.2	165	201	1.2	8	□	2
MPS1-0670-L25C		25	237	168.7	197.2	200	236	1.2	8	□	2
MPS1-0670-L30C		30	272	202.2	232.2	235	271	1.2	8	●	2
MPS1-0670-L35C		35	306	235.7	267.2	269	305	1.2	8	□	2
MPS1-0670-L40C		40	341	269.2	301.2	304	340	1.2	8	●	2
MPS1-0680S-DIN	6.8	3	79	24.0	34	43	77.8	1.2	8	□	4
MPS1-0680S-DIN-C		3	79	24.0	34	43	77.8	1.2	8	●	2
MPS1-0680L-DIN		5	91	43.0	53	55	89.8	1.2	8	□	4
MPS1-0680L-DIN-C		5	91	43.0	53	55	89.8	1.2	8	●	2
MPS1-0680-PC		2	75	14.7	35.1	37	74	1.1	8	●	2
MPS1-0680-L8C		8	118	55.8	78	81	117	1.2	8	●	2
MPS1-0680-L10C		10	132	69.2	92.2	95	131	1.2	8	□	2
MPS1-0680-L12C		12	146	82.8	106.2	109	145	1.2	8	●	2
MPS1-0680-L15C		15	167	103.2	127.2	130	166	1.2	8	●	2
MPS1-0680-L20C		20	202	137.2	162.2	165	201	1.2	8	●	2
MPS1-0680-L25C		25	237	171.2	197.2	200	236	1.2	8	●	2
MPS1-0680-L30C		30	272	205.2	232.2	235	271	1.2	8	●	2
MPS1-0680-L35C		35	306	239.2	267.2	269	305	1.2	8	□	2
MPS1-0680-L40C		40	341	273.2	301.2	304	340	1.2	8	●	2
MPS1-0690S-DIN	6.9	3	79	23.9	34	43	77.7	1.3	8	□	4
MPS1-0690S-DIN-C		3	79	23.9	34	43	77.7	1.3	8	●	2
MPS1-0690L-DIN		5	91	42.9	53	55	89.7	1.3	8	□	4
MPS1-0690L-DIN-C		5	91	42.9	53	55	89.7	1.3	8	●	2
MPS1-0690-PC		2	75	14.9	35.1	37	74	1.1	8	●	2
MPS1-0690-L8C		8	118	56.6	78	81	117	1.3	8	●	2
MPS1-0690-L10C		10	132	70.3	92.3	95	131	1.3	8	□	2
MPS1-0690-L12C		12	146	84.1	106.3	109	145	1.3	8	●	2
MPS1-0690-L15C		15	167	104.8	127.3	130	166	1.3	8	●	2
MPS1-0690-L20C		20	202	139.3	162.3	165	201	1.3	8	●	2
MPS1-0690-L25C		25	237	173.8	197.3	200	236	1.3	8	●	2
MPS1-0690-L30C		30	272	208.3	232.3	235	271	1.3	8	●	2
MPS1-0690-L35C		35	306	242.8	267.3	269	305	1.3	8	□	2
MPS1-0690-L40C		40	341	277.3	301.3	304	340	1.3	8	●	2

# MPS1

## YEKPARE KARBÜR MATKAP

Sipariş Numarası	DC	(l/d)	OAL	LU	LCF	LH	LF	PL	DCON	DP1021	Tür
MPS1-0700S-DIN	7	3	79	23.8	34	43	77.7	1.3	8	□	4
MPS1-0700S-DIN-C		3	79	23.8	34	43	77.7	1.3	8	●	2
MPS1-0700L-DIN		5	91	42.8	53	55	89.7	1.3	8	□	4
MPS1-0700L-DIN-C		5	91	42.8	53	55	89.7	1.3	8	●	2
MPS1-0700-PC		2	75	15.1	35.1	37	74	1.1	8	●	2
MPS1-0700-L8C		8	118	57.4	78	81	117	1.3	8	●	2
MPS1-0700-L10C		10	132	71.3	92.3	95	131	1.3	8	●	2
MPS1-0700-L12C		12	146	85.3	106.3	109	145	1.3	8	●	2
MPS1-0700-L15C		15	167	106.3	127.3	130	166	1.3	8	●	2
MPS1-0700-L20C		20	202	141.3	162.3	165	201	1.3	8	●	2
MPS1-0700-L25C		25	237	176.3	197.3	200	236	1.3	8	●	2
MPS1-0700-L30C		30	272	211.3	232.3	235	271	1.3	8	●	2
MPS1-0700-L35C		35	306	246.3	267.3	269	305	1.3	8	□	2
MPS1-0700-L40C		40	341	281.3	301.3	304	340	1.3	8	●	2
MPS1-0710S-DIN	7.1	3	79	30.6	41	43	77.7	1.3	8	□	4
MPS1-0710S-DIN-C		3	79	30.6	41	43	77.7	1.3	8	●	2
MPS1-0710L-DIN		5	91	42.6	53	55	89.7	1.3	8	□	4
MPS1-0710L-DIN-C		5	91	42.6	53	55	89.7	1.3	8	●	2
MPS1-0710-PC		2	80	15.3	35.1	38	79	1.1	8	●	2
MPS1-0710-L8C		8	124	58.3	84	87	123	1.3	8	●	2
MPS1-0710-L10C		10	139	72.3	99.3	102	138	1.3	8	□	2
MPS1-0710-L12C		12	154	86.5	114.3	117	153	1.3	8	●	2
MPS1-0710-L15C		15	176	107.8	136.3	139	175	1.3	8	●	2
MPS1-0710-L20C		20	214	143.3	174.3	177	213	1.3	8	●	2
MPS1-0710-L25C		25	251	178.8	211.3	214	250	1.3	8	●	2
MPS1-0710-L30C		30	289	214.3	249.3	252	288	1.3	8	●	2
MPS1-0710-L35C		35	325	249.8	286.3	288	324	1.3	8	□	2
MPS1-0710-L40C		40	360	285.3	321.3	323	359	1.3	8	●	2
MPS1-0720S-DIN	7.2	3	79	30.5	41	43	77.7	1.3	8	□	4
MPS1-0720S-DIN-C		3	79	30.5	41	43	77.7	1.3	8	●	2
MPS1-0720L-DIN		5	91	42.5	53	55	89.7	1.3	8	□	4
MPS1-0720L-DIN-C		5	91	42.5	53	55	89.7	1.3	8	●	2
MPS1-0720-PC		2	80	15.5	35.1	38	79	1.1	8	●	2
MPS1-0720-L8C		8	124	59.1	84	87	123	1.3	8	●	2
MPS1-0720-L10C		10	139	73.3	99.3	102	138	1.3	8	□	2
MPS1-0720-L12C		12	154	87.7	114.3	117	153	1.3	8	●	2
MPS1-0720-L15C		15	176	109.3	136.3	139	175	1.3	8	□	2
MPS1-0720-L20C		20	214	145.3	174.3	177	213	1.3	8	□	2
MPS1-0720-L25C		25	251	181.3	211.3	214	250	1.3	8	□	2
MPS1-0720-L30C		30	289	217.3	249.3	252	288	1.3	8	□	2
MPS1-0720-L35C		35	325	253.3	286.3	288	324	1.3	8	□	2
MPS1-0720-L40C		40	360	289.3	321.3	323	359	1.3	8	●	2

# MPS1

## YEKPARE KARBÜR MATKAP

Sipariş Numarası	DC	(l/d)	OAL	LU	LCF	LH	LF	PL	DCON	DP1021	Tür
MPS1-0730S-DIN	7.3	3	79	30.4	41	43	77.7	1.3	8	□	4
MPS1-0730S-DIN-C		3	79	30.4	41	43	77.7	1.3	8	●	2
MPS1-0730L-DIN		5	91	42.4	53	55	89.7	1.3	8	□	4
MPS1-0730L-DIN-C		5	91	42.4	53	55	89.7	1.3	8	●	2
MPS1-0730-PC		2	80	15.8	35.2	38	79	1.2	8	●	2
MPS1-0730-L8C		8	125	59.9	84	88	123	1.3	8	●	2
MPS1-0730-L10C		10	139	74.3	99.3	102	138	1.3	8	□	2
MPS1-0730-L12C		12	154	88.9	114.3	117	153	1.3	8	●	2
MPS1-0730-L15C		15	176	110.8	136.3	139	175	1.3	8	□	2
MPS1-0730-L20C		20	214	147.3	174.3	177	213	1.3	8	□	2
MPS1-0730-L25C		25	251	183.8	211.3	214	250	1.3	8	□	2
MPS1-0730-L30C		30	289	220.3	249.3	252	288	1.3	8	□	2
MPS1-0730-L35C		35	325	256.8	286.3	288	324	1.3	8	□	2
MPS1-0730-L40C		40	360	293.3	321.3	323	359	1.3	8	●	2
MPS1-0740S-DIN	7.4	3	79	30.2	41	43	77.7	1.3	8	□	4
MPS1-0740S-DIN-C		3	79	30.2	41	43	77.7	1.3	8	●	2
MPS1-0740L-DIN		5	91	42.2	53	55	89.7	1.3	8	□	4
MPS1-0740L-DIN-C		5	91	42.2	53	55	89.7	1.3	8	●	2
MPS1-0740-PC		2	80	16	35.2	38	79	1.2	8	●	2
MPS1-0740-L8C		8	125	60.7	84	88	123	1.3	8	●	2
MPS1-0740-L10C		10	139	75.3	99.3	102	138	1.3	8	□	2
MPS1-0740-L12C		12	154	90.1	114.3	117	153	1.3	8	●	2
MPS1-0740-L15C		15	176	112.3	136.3	139	175	1.3	8	□	2
MPS1-0740-L20C		20	214	149.3	174.3	177	213	1.3	8	□	2
MPS1-0740-L25C		25	251	186.3	211.3	214	250	1.3	8	□	2
MPS1-0740-L30C		30	289	223.3	249.3	252	288	1.3	8	□	2
MPS1-0740-L35C		35	325	260.3	286.3	288	324	1.3	8	□	2
MPS1-0740-L40C		40	360	297.3	321.3	323	359	1.3	8	●	2
MPS1-0750S-DIN	7.5	3	79	30.1	41	43	77.6	1.4	8	□	4
MPS1-0750S-DIN-C		3	79	30.1	41	43	77.6	1.4	8	●	2
MPS1-0750L-DIN		5	91	42.1	53	55	89.6	1.4	8	□	4
MPS1-0750L-DIN-C		5	91	42.1	53	55	89.6	1.4	8	●	2
MPS1-0750-PC		2	80	16.2	35.2	38	79	1.2	8	●	2
MPS1-0750-L8C		8	125	61.6	84	88	123	1.4	8	●	2
MPS1-0750-L10C		10	139	76.4	99.4	102	138	1.4	8	□	2
MPS1-0750-L12C		12	154	91.4	114.4	117	153	1.4	8	●	2
MPS1-0750-L15C		15	176	113.9	136.4	139	175	1.4	8	●	2
MPS1-0750-L20C		20	214	151.4	174.4	177	213	1.4	8	●	2
MPS1-0750-L25C		25	251	188.9	211.4	214	250	1.4	8	●	2
MPS1-0750-L30C		30	289	226.4	249.4	252	288	1.4	8	●	2
MPS1-0750-L35C		35	325	263.9	286.4	288	324	1.4	8	□	2
MPS1-0750-L40C		40	360	301.4	321.4	323	359	1.4	8	●	2

# MPS1

## YEKPARE KARBÜR MATKAP

Sipariş Numarası	DC	(l/d)	OAL	LU	LCF	LH	LF	PL	DCON	DP1021	Tür
MPS1-0760S-DIN	7.6	3	79	30.0	41	43	77.6	1.4	8	□	4
MPS1-0760S-DIN-C		3	79	30.0	41	43	77.6	1.4	8	●	2
MPS1-0760L-DIN		5	91	42.0	53	55	89.6	1.4	8	□	4
MPS1-0760L-DIN-C		5	91	42.0	53	55	89.6	1.4	8	●	2
MPS1-0760-PC		2	80	16.4	38.2	38	79	1.2	8	●	2
MPS1-0760-L8C		8	130	62.4	89	93	128	1.4	8	●	2
MPS1-0760-L10C		10	145	77.4	105.4	108	144	1.4	8	□	2
MPS1-0760-L12C		12	161	92.6	121.4	124	160	1.4	8	●	2
MPS1-0760-L15C		15	185	115.4	145.4	148	184	1.4	8	●	2
MPS1-0760-L20C		20	225	153.4	185.4	188	224	1.4	8	□	2
MPS1-0760-L25C		25	265	191.4	225.4	228	264	1.4	8	●	2
MPS1-0760-L30C		30	305	229.4	265.4	268	304	1.4	8	□	2
MPS1-0760-L35C		35	344	267.4	305.4	307	343	1.4	8	□	2
MPS1-0760-L40C		40	379	305.4	341.4	342	378	1.4	8	●	2
MPS1-0770S-DIN	7.7	3	79	29.9	41	43	77.6	1.4	8	□	4
MPS1-0770S-DIN-C		3	79	29.9	41	43	77.6	1.4	8	●	2
MPS1-0770L-DIN		5	91	41.9	53	55	89.6	1.4	8	□	4
MPS1-0770L-DIN-C		5	91	41.9	53	55	89.6	1.4	8	●	2
MPS1-0770-PC		2	80	16.6	38.2	38	79	1.2	8	●	2
MPS1-0770-L8C		8	130	63.2	89	93	128	1.4	8	●	2
MPS1-0770-L10C		10	145	78.4	105.4	108	144	1.4	8	□	2
MPS1-0770-L12C		12	161	93.8	121.4	124	160	1.4	8	●	2
MPS1-0770-L15C		15	185	116.9	145.4	148	184	1.4	8	●	2
MPS1-0770-L20C		20	225	155.4	185.4	188	224	1.4	8	□	2
MPS1-0770-L25C		25	265	193.9	225.4	228	264	1.4	8	●	2
MPS1-0770-L30C		30	305	232.4	265.4	268	304	1.4	8	□	2
MPS1-0770-L35C		35	344	270.9	305.4	307	343	1.4	8	□	2
MPS1-0770-L40C		40	379	309.4	341.4	342	378	1.4	8	●	2
MPS1-0780S-DIN	7.8	3	79	29.7	41	43	77.6	1.4	8	□	4
MPS1-0780S-DIN-C		3	79	29.7	41	43	77.6	1.4	8	●	2
MPS1-0780L-DIN		5	91	41.7	53	55	89.6	1.4	8	□	4
MPS1-0780L-DIN-C		5	91	41.7	53	55	89.6	1.4	8	●	2
MPS1-0780-PC		2	80	16.8	38.2	38	79	1.2	8	●	2
MPS1-0780-L8C		8	130	64.0	89	93	128	1.4	8	●	2
MPS1-0780-L10C		10	145	79.4	105.4	108	144	1.4	8	□	2
MPS1-0780-L12C		12	161	95	121.4	124	160	1.4	8	●	2
MPS1-0780-L15C		15	185	118.4	145.4	148	184	1.4	8	●	2
MPS1-0780-L20C		20	225	157.4	185.4	188	224	1.4	8	□	2
MPS1-0780-L25C		25	265	196.4	225.4	228	264	1.4	8	□	2
MPS1-0780-L30C		30	305	235.4	265.4	268	304	1.4	8	●	2
MPS1-0780-L35C		35	344	274.4	305.4	307	343	1.4	8	□	2
MPS1-0780-L40C		40	379	313.4	341.4	342	378	1.4	8	●	2

# MPS1

## YEKPARE KARBÜR MATKAP

Sipariş Numarası	DC	(l/d)	OAL	LU	LCF	LH	LF	PL	DCON	DP1021	Tür
MPS1-0790S-DIN	7.9	3	79	29.6	41	43	77.6	1.4	8	□	4
MPS1-0790S-DIN-C		3	79	29.6	41	43	77.6	1.4	8	●	2
MPS1-0790L-DIN		5	91	41.6	53	55	89.6	1.4	8	□	4
MPS1-0790L-DIN-C		5	91	41.6	53	55	89.6	1.4	8	●	2
MPS1-0790-PC		2	80	17	38.2	38	79	1.2	8	●	2
MPS1-0790-L8C		8	130	64.8	89	93	128	1.4	8	●	2
MPS1-0790-L10C		10	145	80.4	105.4	108	144	1.4	8	□	2
MPS1-0790-L12C		12	161	96.2	121.4	124	160	1.4	8	●	2
MPS1-0790-L15C		15	185	119.9	145.4	148	184	1.4	8	□	2
MPS1-0790-L20C		20	225	159.4	185.4	188	224	1.4	8	□	2
MPS1-0790-L25C		25	265	198.9	225.4	228	264	1.4	8	●	2
MPS1-0790-L30C		30	305	238.4	265.4	268	304	1.4	8	●	2
MPS1-0790-L35C		35	344	277.9	305.4	307	343	1.4	8	□	2
MPS1-0790-L40C		40	379	317.4	341.4	342	378	1.4	8	●	2
MPS1-0800S-DIN	8	3	79	29.5	41	43	77.5	1.5	8	□	4
MPS1-0800S-DIN-C		3	79	29.5	41	43	77.5	1.5	8	●	2
MPS1-0800L-DIN		5	91	41.5	53	55	89.5	1.5	8	□	4
MPS1-0800L-DIN-C		5	91	41.5	53	55	89.5	1.5	8	●	2
MPS1-0800-PC		2	80	17.3	38.3	38	79	1.3	8	●	2
MPS1-0800-L8C		8	130	65.7	89	93	128	1.5	8	●	2
MPS1-0800-L10C		10	145	81.5	105.5	108	144	1.5	8	●	2
MPS1-0800-L12C		12	161	97.5	121.5	124	160	1.5	8	●	2
MPS1-0800-L15C		15	185	121.5	145.5	148	184	1.5	8	●	2
MPS1-0800-L20C		20	225	161.5	185.5	188	224	1.5	8	●	2
MPS1-0800-L25C		25	265	201.5	225.5	228	264	1.5	8	●	2
MPS1-0800-L30C		30	305	241.5	265.5	268	304	1.5	8	●	2
MPS1-0800-L35C		35	344	281.5	305.5	307	343	1.5	8	□	2
MPS1-0800-L40C		40	379	321.5	341.5	342	378	1.5	8	●	2
MPS1-0805S-DIN	8.05	3	88	34.4	46	48	86.5	1.5	10	□	4
MPS1-0805S-DIN-C		3	88	34.4	46	48	86.5	1.5	10	●	2
MPS1-0805L-DIN		5	102	48.4	60	62	100.5	1.5	10	□	4
MPS1-0805L-DIN-C		5	102	48.4	60	62	100.5	1.5	10	●	2
MPS1-0810S-DIN	8.1	3	88	34.3	46	48	86.5	1.5	10	□	4
MPS1-0810S-DIN-C		3	88	34.3	46	48	86.5	1.5	10	●	2
MPS1-0810L-DIN		5	102	48.3	60	62	100.5	1.5	10	□	4
MPS1-0810L-DIN-C		5	102	48.3	60	62	100.5	1.5	10	●	2
MPS1-0810-PC		2	85	17.5	38.3	41	84	1.3	10	●	2
MPS1-0810-L8C		8	140	66.5	95	99	138	1.5	10	●	2
MPS1-0810-L10C		10	156	82.5	112.5	115	155	1.5	10	□	2
MPS1-0810-L12C		12	173	98.7	129.5	132	172	1.5	10	●	2
MPS1-0810-L15C		15	198	123	154.5	157	197	1.5	10	●	2
MPS1-0810-L20C		20	241	163.5	197.5	200	240	1.5	10	●	2
MPS1-0810-L25C		25	283	204	239.5	242	282	1.5	10	□	2
MPS1-0810-L30C		30	325	244.5	282.5	284	324	1.5	10	□	2
MPS1-0810-L35C		35	367	285	324.5	326	366	1.5	10	□	2
MPS1-0810-L40C		40	411	325.5	366.5	370	410	1.5	10	●	2

# MPS1

## YEKPARE KARBÜR MATKAP

Sipariş Numarası	DC	(l/d)	OAL	LU	LCF	LH	LF	PL	DCON	DP1021	Tür
MPS1-0820S-DIN	8.2	3	88	34.2	46	48	86.5	1.5	10	□	4
MPS1-0820S-DIN-C		3	88	34.2	46	48	86.5	1.5	10	●	2
MPS1-0820L-DIN		5	102	48.2	60	62	100.5	1.5	10	□	4
MPS1-0820L-DIN-C		5	102	48.2	60	62	100.5	1.5	10	●	2
MPS1-0820-PC		2	85	17.7	38.3	41	84	1.3	10	●	2
MPS1-0820-L8C		8	140	67.3	95	99	138	1.5	10	●	2
MPS1-0820-L10C		10	156	83.5	112.5	115	155	1.5	10	□	2
MPS1-0820-L12C		12	173	99.9	129.5	132	172	1.5	10	●	2
MPS1-0820-L15C		15	198	124.5	154.5	157	197	1.5	10	●	2
MPS1-0820-L20C		20	241	165.5	197.5	200	240	1.5	10	●	2
MPS1-0820-L25C		25	283	206.5	239.5	242	282	1.5	10	□	2
MPS1-0820-L30C		30	325	247.5	282.5	284	324	1.5	10	□	2
MPS1-0820-L35C		35	367	288.5	324.5	326	366	1.5	10	□	2
MPS1-0820-L40C		40	411	329.5	366.5	370	410	1.5	10	●	2
MPS1-0830S-DIN	8.3	3	88	34.1	46	48	86.5	1.5	10	□	4
MPS1-0830S-DIN-C		3	88	34.1	46	48	86.5	1.5	10	●	2
MPS1-0830L-DIN		5	102	48.1	60	62	100.5	1.5	10	□	4
MPS1-0830L-DIN-C		5	102	48.1	60	62	100.5	1.5	10	●	2
MPS1-0830-PC		2	85	17.9	38.3	41	84	1.3	10	●	2
MPS1-0830-L8C		8	140	68.1	95	99	138	1.5	10	●	2
MPS1-0830-L10C		10	157	84.5	112.5	116	155	1.5	10	□	2
MPS1-0830-L12C		12	174	101.1	129.5	133	172	1.5	10	●	2
MPS1-0830-L15C		15	199	126	154.5	158	197	1.5	10	□	2
MPS1-0830-L20C		20	242	167.5	197.5	201	240	1.5	10	□	2
MPS1-0830-L25C		25	284	209	239.5	243	282	1.5	10	□	2
MPS1-0830-L30C		30	326	250.5	282.5	285	324	1.5	10	□	2
MPS1-0830-L35C		35	368	292	324.5	327	366	1.5	10	□	2
MPS1-0830-L40C		40	412	333.5	366.5	371	410	1.5	10	●	2
MPS1-0840S-DIN	8.4	3	88	33.9	46	48	86.5	1.5	10	□	4
MPS1-0840S-DIN-C		3	88	33.9	46	48	86.5	1.5	10	●	2
MPS1-0840L-DIN		5	102	47.9	60	62	100.5	1.5	10	□	4
MPS1-0840L-DIN-C		5	102	47.9	60	62	100.5	1.5	10	●	2
MPS1-0840-PC		2	85	18.1	38.3	41	84	1.3	10	●	2
MPS1-0840-L8C		8	140	68.9	95	99	138	1.5	10	●	2
MPS1-0840-L10C		10	157	85.5	112.5	116	155	1.5	10	□	2
MPS1-0840-L12C		12	174	102.3	129.5	133	172	1.5	10	●	2
MPS1-0840-L15C		15	199	127.5	154.5	158	197	1.5	10	●	2
MPS1-0840-L20C		20	242	169.5	197.5	201	240	1.5	10	□	2
MPS1-0840-L25C		25	284	211.5	239.5	243	282	1.5	10	□	2
MPS1-0840-L30C		30	326	253.5	282.5	285	324	1.5	10	□	2
MPS1-0840-L35C		35	368	295.5	324.5	327	366	1.5	10	□	2
MPS1-0840-L40C		40	412	337.5	366.5	371	410	1.5	10	●	2

# MPS1

## YEKPARE KARBÜR MATKAP

Sipariş Numarası	DC	(l/d)	OAL	LU	LCF	LH	LF	PL	DCON	DP1021	Tür
MPS1-0850S-DIN	8.5	3	88	33.8	46	48	86.5	1.5	10	□	4
MPS1-0850S-DIN-C		3	88	33.8	46	48	86.5	1.5	10	●	2
MPS1-0850L-DIN		5	102	47.8	60	62	100.5	1.5	10	□	4
MPS1-0850L-DIN-C		5	102	47.8	60	62	100.5	1.5	10	●	2
MPS1-0850-PC		2	85	18.3	38.3	41	84	1.3	10	●	2
MPS1-0850-L8C		8	140	69.8	95	99	138	1.5	10	●	2
MPS1-0850-L10C		10	157	86.5	112.5	116	155	1.5	10	□	2
MPS1-0850-L12C		12	174	103.5	129.5	133	172	1.5	10	●	2
MPS1-0850-L15C		15	199	129	154.5	158	197	1.5	10	●	2
MPS1-0850-L20C		20	242	171.5	197.5	201	240	1.5	10	●	2
MPS1-0850-L25C		25	284	214	239.5	243	282	1.5	10	●	2
MPS1-0850-L30C		30	326	256.5	282.5	285	324	1.5	10	●	2
MPS1-0850-L35C		35	368	299	324.5	327	366	1.5	10	□	2
MPS1-0850-L40C		40	412	341.5	366.5	371	410	1.5	10	●	2
MPS1-0860S-DIN		8.6	3	88	33.7	46	48	86.4	1.6	10	□
MPS1-0860S-DIN-C	3		88	33.7	46	48	86.4	1.6	10	●	2
MPS1-0860L-DIN	5		102	47.7	60	62	100.4	1.6	10	□	4
MPS1-0860L-DIN-C	5		102	47.7	60	62	100.4	1.6	10	●	2
MPS1-0860-PC	2		85	18.6	41.4	43	84	1.4	10	●	2
MPS1-0860-L8C	8		145	70.6	100	104	143	1.6	10	●	2
MPS1-0860-L10C	10		163	87.6	118.6	122	161	1.6	10	□	2
MPS1-0860-L12C	12		181	104.8	136.6	140	179	1.6	10	●	2
MPS1-0860-L15C	15		208	130.6	163.6	167	206	1.6	10	●	2
MPS1-0860-L20C	20		253	173.6	208.6	212	251	1.6	10	□	2
MPS1-0860-L25C	25		298	216.6	253.6	257	296	1.6	10	●	2
MPS1-0860-L30C	30		342	259.6	298.6	301	340	1.6	10	●	2
MPS1-0860-L35C	35		387	302.6	343.6	346	385	1.6	10	□	2
MPS1-0860-L40C	40		436	345.6	391.6	395	434	1.6	10	●	2
MPS1-0870S-DIN	8.7		3	88	33.5	46	48	86.4	1.6	10	□
MPS1-0870S-DIN-C		3	88	33.5	46	48	86.4	1.6	10	●	2
MPS1-0870L-DIN		5	102	47.5	60	62	100.4	1.6	10	□	4
MPS1-0870L-DIN-C		5	102	47.5	60	62	100.4	1.6	10	●	2
MPS1-0870-PC		2	85	18.8	41.4	43	84	1.4	10	●	2
MPS1-0870-L8C		8	145	71.4	100	104	143	1.6	10	●	2
MPS1-0870-L10C		10	163	88.6	118.6	122	161	1.6	10	□	2
MPS1-0870-L12C		12	181	106	136.6	140	179	1.6	10	●	2
MPS1-0870-L15C		15	208	132.1	163.6	167	206	1.6	10	●	2
MPS1-0870-L20C		20	253	175.6	208.6	212	251	1.6	10	□	2
MPS1-0870-L25C		25	298	219.1	253.6	257	296	1.6	10	●	2
MPS1-0870-L30C		30	342	262.6	298.6	301	340	1.6	10	□	2
MPS1-0870-L35C		35	387	306.1	343.6	346	385	1.6	10	□	2
MPS1-0870-L40C		40	436	349.6	391.6	395	434	1.6	10	●	2



# MPS1

## YEKPARE KARBÜR MATKAP

Sipariş Numarası	DC	(l/d)	OAL	LU	LCF	LH	LF	PL	DCON	DP1021	Tür	
MPS1-0880S-DIN	8.8	3	88	33.4	46	48	86.4	1.6	10	□	4	
MPS1-0880S-DIN-C		3	88	33.4	46	48	86.4	1.6	10	●	2	
MPS1-0880L-DIN		5	102	47.4	60	62	100.4	1.6	10	□	4	
MPS1-0880L-DIN-C		5	102	47.4	60	62	100.4	1.6	10	●	2	
MPS1-0880-PC		2	85	19	41.4	43	84	1.4	10	●	2	
MPS1-0880-L8C		8	145	72.2	100	104	143	1.6	10	●	2	
MPS1-0880-L10C		10	163	89.6	118.6	122	161	1.6	10	□	2	
MPS1-0880-L12C		12	181	107.2	136.6	140	179	1.6	10	●	2	
MPS1-0880-L15C		15	208	133.6	163.6	167	206	1.6	10	●	2	
MPS1-0880-L20C		20	253	177.6	208.6	212	251	1.6	10	●	2	
MPS1-0880-L25C		25	298	221.6	253.6	257	296	1.6	10	●	2	
MPS1-0880-L30C		30	342	265.6	298.6	301	340	1.6	10	●	2	
MPS1-0880-L35C		35	387	309.6	343.6	346	385	1.6	10	□	2	
MPS1-0880-L40C		40	436	353.6	391.6	395	434	1.6	10	●	2	
MPS1-0890S-DIN		8.9	3	88	33.3	46	48	86.4	1.6	10	□	4
MPS1-0890S-DIN-C			3	88	33.3	46	48	86.4	1.6	10	●	2
MPS1-0890L-DIN	5		102	47.3	60	62	100.4	1.6	10	□	4	
MPS1-0890L-DIN-C	5		102	47.3	60	62	100.4	1.6	10	●	2	
MPS1-0890-PC	2		85	19.2	41.4	43	84	1.4	10	●	2	
MPS1-0890-L8C	8		145	73.0	100	104	143	1.6	10	●	2	
MPS1-0890-L10C	10		163	90.6	118.6	122	161	1.6	10	□	2	
MPS1-0890-L12C	12		181	108.4	136.6	140	179	1.6	10	●	2	
MPS1-0890-L15C	15		208	135.1	163.6	167	206	1.6	10	□	2	
MPS1-0890-L20C	20		253	179.6	208.6	212	251	1.6	10	□	2	
MPS1-0890-L25C	25		298	224.1	253.6	257	296	1.6	10	□	2	
MPS1-0890-L30C	30		342	268.6	298.6	301	340	1.6	10	□	2	
MPS1-0890-L35C	35		387	313.1	343.6	346	385	1.6	10	□	2	
MPS1-0890-L40C	40		436	357.6	391.6	395	434	1.6	10	●	2	
MPS1-0900S-DIN	9		3	88	33.1	46	48	86.4	1.6	10	□	4
MPS1-0900S-DIN-C			3	88	33.1	46	48	86.4	1.6	10	●	2
MPS1-0900L-DIN		5	102	47.1	60	62	100.4	1.6	10	□	4	
MPS1-0900L-DIN-C		5	102	47.1	60	62	100.4	1.6	10	●	2	
MPS1-0900-PC		2	85	19.4	41.4	43	84	1.4	10	●	2	
MPS1-0900-L8C		8	145	73.9	100	104	143	1.6	10	●	2	
MPS1-0900-L10C		10	163	91.6	118.6	122	161	1.6	10	●	2	
MPS1-0900-L12C		12	181	109.6	136.6	140	179	1.6	10	●	2	
MPS1-0900-L15C		15	208	136.6	163.6	167	206	1.6	10	●	2	
MPS1-0900-L20C		20	253	181.6	208.6	212	251	1.6	10	●	2	
MPS1-0900-L25C		25	298	226.6	253.6	257	296	1.6	10	●	2	
MPS1-0900-L30C		30	342	271.6	298.6	301	340	1.6	10	●	2	
MPS1-0900-L35C		35	387	316.6	343.6	346	385	1.6	10	□	2	
MPS1-0900-L40C		40	436	361.6	391.6	395	434	1.6	10	●	2	

# MPS1

## YEKPARE KARBÜR MATKAP

Sipariş Numarası	DC	(l/d)	OAL	LU	LCF	LH	LF	PL	DCON	DP1021	Tür	
MPS1-0910S-DIN	9.1	3	89	33.0	47	49	87.3	1.7	10	□	4	
MPS1-0910S-DIN-C		3	89	33.0	47	49	87.3	1.7	10	●	2	
MPS1-0910L-DIN		5	103	47.0	62	63	101.3	1.7	10	□	4	
MPS1-0910L-DIN-C		5	103	47.0	62	63	101.3	1.7	10	●	2	
MPS1-0910-PC		2	90	19.6	41.4	44	89	1.4	10	●	2	
MPS1-0910-L8C		8	151	74.7	107	110	149	1.7	10	●	2	
MPS1-0910-L10C		10	170	92.7	125.7	129	168	1.7	10	□	2	
MPS1-0910-L12C		12	189	110.9	144.7	148	187	1.7	10	●	2	
MPS1-0910-L15C		15	217	138.2	172.7	176	215	1.7	10	●	2	
MPS1-0910-L20C		20	265	183.7	220.7	224	263	1.7	10	□	2	
MPS1-0910-L25C		25	312	229.2	267.7	271	310	1.7	10	□	2	
MPS1-0910-L30C		30	360	274.7	315.7	319	358	1.7	10	●	2	
MPS1-0910-L35C		35	406	320.2	362.7	365	404	1.7	10	□	2	
MPS1-0920S-DIN		9.2	3	89	32.9	47	49	87.3	1.7	10	□	4
MPS1-0920S-DIN-C			3	89	32.9	47	49	87.3	1.7	10	●	2
MPS1-0920L-DIN	5		103	46.9	62	63	101.3	1.7	10	□	4	
MPS1-0920L-DIN-C	5		103	46.9	62	63	101.3	1.7	10	●	2	
MPS1-0920-PC	2		90	19.9	41.5	44	89	1.5	10	●	2	
MPS1-0920-L8C	8		151	75.5	107	110	149	1.7	10	●	2	
MPS1-0920-L10C	10		170	93.7	125.7	129	168	1.7	10	□	2	
MPS1-0920-L12C	12		189	112.1	144.7	148	187	1.7	10	●	2	
MPS1-0920-L15C	15		217	139.7	172.7	176	215	1.7	10	●	2	
MPS1-0920-L20C	20		265	185.7	220.7	224	263	1.7	10	□	2	
MPS1-0920-L25C	25		312	231.7	267.7	271	310	1.7	10	□	2	
MPS1-0920-L30C	30		360	277.7	315.7	319	358	1.7	10	□	2	
MPS1-0920-L35C	35		406	323.7	362.7	365	404	1.7	10	□	2	
MPS1-0930S-DIN	9.3		3	89	32.7	47	49	87.3	1.7	10	□	4
MPS1-0930S-DIN-C			3	89	32.7	47	49	87.3	1.7	10	●	2
MPS1-0930L-DIN		5	103	46.7	62	63	101.3	1.7	10	□	4	
MPS1-0930L-DIN-C		5	103	46.7	62	63	101.3	1.7	10	●	2	
MPS1-0930-PC		2	90	20.1	41.5	44	89	1.5	10	●	2	
MPS1-0930-L8C		8	151	76.3	107	110	149	1.7	10	●	2	
MPS1-0930-L10C		10	170	94.7	125.7	129	168	1.7	10	□	2	
MPS1-0930-L12C		12	189	113.3	144.7	148	187	1.7	10	●	2	
MPS1-0930-L15C		15	217	141.2	172.7	176	215	1.7	10	□	2	
MPS1-0930-L20C		20	265	187.7	220.7	224	263	1.7	10	□	2	
MPS1-0930-L25C		25	312	234.2	267.7	271	310	1.7	10	□	2	
MPS1-0930-L30C		30	360	280.7	315.7	319	358	1.7	10	□	2	
MPS1-0930-L35C		35	406	327.2	362.7	365	404	1.7	10	□	2	

# MPS1

## YEKPARE KARBÜR MATKAP

Sipariş Numarası	DC	(l/d)	OAL	LU	LCF	LH	LF	PL	DCON	DP1021	Tür
MPS1-0940S-DIN		3	89	32.6	47	49	87.3	1.7	10	□	4
MPS1-0940S-DIN-C		3	89	32.6	47	49	87.3	1.7	10	●	2
MPS1-0940L-DIN		5	103	46.6	62	63	101.3	1.7	10	□	4
MPS1-0940L-DIN-C		5	103	46.6	62	63	101.3	1.7	10	●	2
MPS1-0940-PC		2	90	20.3	41.5	44	89	1.5	10	●	2
MPS1-0940-L8C		8	151	77.1	107	110	149	1.7	10	●	2
MPS1-0940-L10C	9.4	10	170	95.7	125.7	129	168	1.7	10	□	2
MPS1-0940-L12C		12	189	114.5	144.7	148	187	1.7	10	●	2
MPS1-0940-L15C		15	216	142.7	172.7	175	215	1.7	10	□	2
MPS1-0940-L20C		20	264	189.7	220.7	223	263	1.7	10	□	2
MPS1-0940-L25C		25	311	236.7	267.7	270	310	1.7	10	□	2
MPS1-0940-L30C		30	359	283.7	315.7	318	358	1.7	10	□	2
MPS1-0940-L35C		35	406	330.7	362.7	365	404	1.7	10	□	2
MPS1-0950S-DIN		3	89	32.5	47	49	87.3	1.7	10	□	4
MPS1-0950S-DIN-C		3	89	32.5	47	49	87.3	1.7	10	●	2
MPS1-0950L-DIN		5	103	46.5	62	63	101.3	1.7	10	□	4
MPS1-0950L-DIN-C		5	103	46.5	62	63	101.3	1.7	10	●	2
MPS1-0950-PC		2	90	20.5	41.5	44	89	1.5	10	●	2
MPS1-0950-L8C		8	151	78.0	107	110	149	1.7	10	●	2
MPS1-0950-L10C	9.5	10	169	96.7	125.7	128	168	1.7	10	□	2
MPS1-0950-L12C		12	188	115.7	144.7	147	187	1.7	10	●	2
MPS1-0950-L15C		15	216	144.2	172.7	175	215	1.7	10	●	2
MPS1-0950-L20C		20	265	191.7	220.7	224	263	1.7	10	●	2
MPS1-0950-L25C		25	311	239.2	267.7	270	310	1.7	10	●	2
MPS1-0950-L30C		30	359	286.7	315.7	318	358	1.7	10	●	2
MPS1-0950-L35C		35	405	334.2	362.7	364	404	1.7	10	□	2
MPS1-0960S-DIN		3	89	32.3	47	49	87.3	1.7	10	□	4
MPS1-0960S-DIN-C		3	89	32.3	47	49	87.3	1.7	10	●	2
MPS1-0960L-DIN		5	103	46.3	62	63	101.3	1.7	10	□	4
MPS1-0960L-DIN-C		5	103	46.3	62	63	101.3	1.7	10	●	2
MPS1-0960-PC		2	90	20.7	44.5	44	89	1.5	10	●	2
MPS1-0960-L8C		8	156	78.8	112	115	154	1.7	10	●	2
MPS1-0960-L10C	9.6	10	176	97.7	131.7	135	174	1.7	10	□	2
MPS1-0960-L12C		12	195	116.9	151.7	154	194	1.7	10	●	2
MPS1-0960-L15C		15	225	145.7	181.7	184	224	1.7	10	●	2
MPS1-0960-L20C		20	275	193.7	231.7	234	274	1.7	10	□	2
MPS1-0960-L25C		25	325	241.7	281.7	284	324	1.7	10	□	2
MPS1-0960-L30C		30	375	289.7	331.7	334	374	1.7	10	□	2
MPS1-0960-L35C		35	424	337.7	381.7	383	423	1.7	10	□	2

# MPS1

## YEKPARE KARBÜR MATKAP

Sipariş Numarası	DC	(l/d)	OAL	LU	LCF	LH	LF	PL	DCON	DP1021	Tür	
MPS1-0970S-DIN	9.7	3	89	32.2	47	49	87.2	1.8	10	□	4	
MPS1-0970S-DIN-C		3	89	32.2	47	49	87.2	1.8	10	●	2	
MPS1-0970L-DIN		5	103	46.2	62	63	101.2	1.8	10	□	4	
MPS1-0970L-DIN-C		5	103	46.2	62	63	101.2	1.8	10	●	2	
MPS1-0970-PC		2	90	20.9	44.5	44	89	1.5	10	●	2	
MPS1-0970-L8C		8	156	79.6	112	115	154	1.8	10	●	2	
MPS1-0970-L10C		10	175	98.8	131.8	134	174	1.8	10	□	2	
MPS1-0970-L12C		12	195	118.2	151.8	154	194	1.8	10	●	2	
MPS1-0970-L15C		15	225	147.3	181.8	184	224	1.8	10	●	2	
MPS1-0970-L20C		20	275	195.8	231.8	234	274	1.8	10	□	2	
MPS1-0970-L25C		25	325	244.3	281.8	284	324	1.8	10	□	2	
MPS1-0970-L30C		30	376	292.8	331.8	335	374	1.8	10	□	2	
MPS1-0970-L35C		35	425	341.3	381.8	384	423	1.8	10	□	2	
MPS1-0980S-DIN		9.8	3	89	32.1	47	49	87.2	1.8	10	□	4
MPS1-0980S-DIN-C			3	89	32.1	47	49	87.2	1.8	10	●	2
MPS1-0980L-DIN	5		103	46.1	62	63	101.2	1.8	10	□	4	
MPS1-0980L-DIN-C	5		103	46.1	62	63	101.2	1.8	10	●	2	
MPS1-0980-PC	2		91	21.1	44.5	45	89	1.5	10	●	2	
MPS1-0980-L8C	8		156	80.4	112	115	154	1.8	10	●	2	
MPS1-0980-L10C	10		176	99.8	131.8	135	174	1.8	10	□	2	
MPS1-0980-L12C	12		196	119.4	151.8	155	194	1.8	10	●	2	
MPS1-0980-L15C	15		226	148.8	181.8	185	224	1.8	10	●	2	
MPS1-0980-L20C	20		276	197.8	231.8	235	274	1.8	10	●	2	
MPS1-0980-L25C	25		326	246.8	281.8	285	324	1.8	10	□	2	
MPS1-0980-L30C	30		376	295.8	331.8	335	374	1.8	10	●	2	
MPS1-0980-L35C	35		425	344.8	381.8	384	423	1.8	10	□	2	
MPS1-0990S-DIN	9.9		3	89	32.0	47	49	87.2	1.8	10	□	4
MPS1-0990S-DIN-C			3	89	32.0	47	49	87.2	1.8	10	●	2
MPS1-0990L-DIN		5	103	46.0	62	63	101.2	1.8	10	□	4	
MPS1-0990L-DIN-C		5	103	46.0	62	63	101.2	1.8	10	●	2	
MPS1-0990-PC		2	91	21.4	44.6	45	89	1.6	10	●	2	
MPS1-0990-L8C		8	156	81.3	112	115	154	1.8	10	●	2	
MPS1-0990-L10C		10	176	100.8	131.8	135	174	1.8	10	□	2	
MPS1-0990-L12C		12	196	120.6	151.8	155	194	1.8	10	●	2	
MPS1-0990-L15C		15	226	150.3	181.8	185	224	1.8	10	●	2	
MPS1-0990-L20C		20	276	199.8	231.8	235	274	1.8	10	□	2	
MPS1-0990-L25C		25	326	249.3	281.8	285	324	1.8	10	□	2	
MPS1-0990-L30C		30	376	298.8	331.8	335	374	1.8	10	□	2	
MPS1-0990-L35C		35	425	348.3	381.8	384	423	1.8	10	□	2	

# MPS1

## YEKPARE KARBÜR MATKAP

Sipariş Numarası	DC	(l/d)	OAL	LU	LCF	LH	LF	PL	DCON	DP1021	Tür
MPS1-1000S-DIN	10	3	89	31.8	47	49	87.2	1.8	10	□	4
MPS1-1000S-DIN-C		3	89	31.8	47	49	87.2	1.8	10	●	2
MPS1-1000L-DIN		5	103	45.8	62	63	101.2	1.8	10	□	4
MPS1-1000L-DIN-C		5	103	45.8	62	63	101.2	1.8	10	●	2
MPS1-1000-PC		2	91	21.6	44.6	45	89	1.6	10	●	2
MPS1-1000-L8C		8	156	82.1	112	115	154	1.8	10	●	2
MPS1-1000-L10C		10	176	101.8	131.8	135	174	1.8	10	●	2
MPS1-1000-L12C		12	196	121.8	151.8	155	194	1.8	10	●	2
MPS1-1000-L15C		15	226	151.8	181.8	185	224	1.8	10	●	2
MPS1-1000-L20C		20	276	201.8	231.8	235	274	1.8	10	●	2
MPS1-1000-L25C		25	326	251.8	281.8	285	324	1.8	10	●	2
MPS1-1000-L30C		30	376	301.8	331.8	335	374	1.8	10	●	2
MPS1-1000-L35C		35	425	351.8	381.8	384	423	1.8	10	□	2
MPS1-1005S-DIN		10.05	3	102	39.8	55	57	100.2	1.8	12	□
MPS1-1005S-DIN-C	3		102	39.8	55	57	100.2	1.8	12	●	2
MPS1-1005L-DIN	5		118	55.8	71	73	116.2	1.8	12	□	4
MPS1-1005L-DIN-C	5		118	55.8	71	73	116.2	1.8	12	●	2
MPS1-1010S-DIN	10.1	3	102	39.7	55	57	100.2	1.8	12	□	4
MPS1-1010S-DIN-C		3	102	39.7	55	57	100.2	1.8	12	●	2
MPS1-1010L-DIN		5	118	55.7	71	73	116.2	1.8	12	□	4
MPS1-1010L-DIN-C		5	118	55.7	71	73	116.2	1.8	12	●	2
MPS1-1010-PC		2	97	21.8	44.6	48	95	1.6	12	●	2
MPS1-1010-L8C		8	167	82.9	118	121	165	1.8	12	●	2
MPS1-1010-L10C		10	188	102.8	138.8	142	186	1.8	12	□	2
MPS1-1010-L12C		12	209	123	159.8	163	207	1.8	12	●	2
MPS1-1010-L15C		15	240	153.3	190.8	194	238	1.8	12	●	2
MPS1-1010-L20C		20	293	203.8	243.8	247	291	1.8	12	●	2
MPS1-1010-L25C		25	345	254.3	295.8	299	343	1.8	12	□	2
MPS1-1020S-DIN		10.2	3	102	39.6	55	57	100.1	1.9	12	□
MPS1-1020S-DIN-C	3		102	39.6	55	57	100.1	1.9	12	●	2
MPS1-1020L-DIN	5		118	55.6	71	73	116.1	1.9	12	□	4
MPS1-1020L-DIN-C	5		118	55.6	71	73	116.1	1.9	12	●	2
MPS1-1020-PC	2		96	22	44.6	47	95	1.6	12	●	2
MPS1-1020-L8C	8		167	83.7	118	121	165	1.9	12	●	2
MPS1-1020-L10C	10		187	103.9	138.9	141	186	1.9	12	□	2
MPS1-1020-L12C	12		208	124.3	159.9	162	207	1.9	12	●	2
MPS1-1020-L15C	15		239	154.9	190.9	193	238	1.9	12	●	2
MPS1-1020-L20C	20		292	205.9	243.9	246	291	1.9	12	●	2
MPS1-1020-L25C	25	344	256.9	295.9	298	343	1.9	12	□	2	

# MPS1

## YEKPARE KARBÜR MATKAP

Sipariş Numarası	DC	(l/d)	OAL	LU	LCF	LH	LF	PL	DCON	DP1021	Tür
MPS1-1030S-DIN	10.3	3	102	39.4	55	57	100.1	1.9	12	□	4
MPS1-1030S-DIN-C		3	102	39.4	55	57	100.1	1.9	12	●	2
MPS1-1030L-DIN		5	118	55.4	71	73	116.1	1.9	12	□	4
MPS1-1030L-DIN-C		5	118	55.4	71	73	116.1	1.9	12	●	2
MPS1-1030-PC		2	96	22.2	44.6	47	95	1.6	12	●	2
MPS1-1030-L8C		8	167	84.5	118	121	165	1.9	12	●	2
MPS1-1030-L10C		10	187	104.9	138.9	141	186	1.9	12	□	2
MPS1-1030-L12C		12	208	125.5	159.9	162	207	1.9	12	●	2
MPS1-1030-L15C		15	239	156.4	190.9	193	238	1.9	12	□	2
MPS1-1030-L20C		20	292	207.9	243.9	246	291	1.9	12	□	2
MPS1-1030-L25C		25	344	259.4	295.9	298	343	1.9	12	□	2
MPS1-1040S-DIN	10.4	3	102	39.3	55	57	100.1	1.9	12	□	4
MPS1-1040S-DIN-C		3	102	39.3	55	57	100.1	1.9	12	●	2
MPS1-1040L-DIN		5	118	55.3	71	73	116.1	1.9	12	□	4
MPS1-1040L-DIN-C		5	118	55.3	71	73	116.1	1.9	12	●	2
MPS1-1040-PC		2	96	22.4	44.6	47	95	1.6	12	●	2
MPS1-1040-L8C		8	167	85.4	118	121	165	1.9	12	●	2
MPS1-1040-L10C		10	187	105.9	138.9	141	186	1.9	12	□	2
MPS1-1040-L12C		12	208	126.7	159.9	162	207	1.9	12	●	2
MPS1-1040-L15C		15	239	157.9	190.9	193	238	1.9	12	□	2
MPS1-1040-L20C		20	292	209.9	243.9	246	291	1.9	12	□	2
MPS1-1040-L25C		25	344	261.9	295.9	298	343	1.9	12	□	2
MPS1-1050S-DIN	10.5	3	102	39.2	55	57	100.1	1.9	12	□	4
MPS1-1050S-DIN-C		3	102	39.2	55	57	100.1	1.9	12	●	2
MPS1-1050L-DIN		5	118	55.2	71	73	116.1	1.9	12	□	4
MPS1-1050L-DIN-C		5	118	55.2	71	73	116.1	1.9	12	●	2
MPS1-1050-PC		2	96	22.7	44.7	47	95	1.7	12	●	2
MPS1-1050-L8C		8	167	86.2	118	121	165	1.9	12	●	2
MPS1-1050-L10C		10	187	106.9	138.9	141	186	1.9	12	□	2
MPS1-1050-L12C		12	208	127.9	159.9	162	207	1.9	12	●	2
MPS1-1050-L15C		15	239	159.4	190.9	193	238	1.9	12	●	2
MPS1-1050-L20C		20	292	211.9	243.9	246	291	1.9	12	●	2
MPS1-1050-L25C		25	344	264.4	295.9	298	343	1.9	12	●	2
MPS1-1060S-DIN	10.6	3	102	39.0	55	57	100.1	1.9	12	□	4
MPS1-1060S-DIN-C		3	102	39.0	55	57	100.1	1.9	12	●	2
MPS1-1060L-DIN		5	118	55.0	71	73	116.1	1.9	12	□	4
MPS1-1060L-DIN-C		5	118	55.0	71	73	116.1	1.9	12	●	2
MPS1-1060-PC		2	96	22.9	48.7	49	95	1.7	12	□	2
MPS1-1060-L8C		8	172	87.0	123	126	170	1.9	12	●	2
MPS1-1060-L10C		10	193	107.9	144.9	147	192	1.9	12	□	2
MPS1-1060-L12C		12	215	129.1	166.9	169	214	1.9	12	□	2
MPS1-1060-L15C		15	248	160.9	199.9	202	247	1.9	12	□	2
MPS1-1060-L20C		20	303	213.9	254.9	257	302	1.9	12	□	2
MPS1-1060-L25C		25	358	266.9	309.9	312	357	1.9	12	□	2

# MPS1

## YEKPARE KARBÜR MATKAP

Sipariş Numarası	DC	(l/d)	OAL	LU	LCF	LH	LF	PL	DCON	DP1021	Tür
MPS1-1070S-DIN	10.7	3	102	38.9	55	57	100.1	1.9	12	□	4
MPS1-1070S-DIN-C		3	102	38.9	55	57	100.1	1.9	12	●	2
MPS1-1070L-DIN		5	118	54.9	71	73	116.1	1.9	12	□	4
MPS1-1070L-DIN-C		5	118	54.9	71	73	116.1	1.9	12	●	2
MPS1-1070-PC		2	96	23.1	48.7	49	95	1.7	12	●	2
MPS1-1070-L8C		8	172	87.8	123	126	170	1.9	12	●	2
MPS1-1070-L10C		10	193	108.9	144.9	147	192	1.9	12	□	2
MPS1-1070-L12C		12	215	130.3	166.9	169	214	1.9	12	●	2
MPS1-1070-L15C		15	248	162.4	199.9	202	247	1.9	12	□	2
MPS1-1070-L20C		20	303	215.9	254.9	257	302	1.9	12	□	2
MPS1-1070-L25C		25	358	269.4	309.9	312	357	1.9	12	□	2
MPS1-1080S-DIN	10.8	3	102	38.8	55	57	100	2.0	12	□	4
MPS1-1080S-DIN-C		3	102	38.8	55	57	100	2.0	12	●	2
MPS1-1080L-DIN		5	118	54.8	71	73	116	2.0	12	□	4
MPS1-1080L-DIN-C		5	118	54.8	71	73	116	2.0	12	●	2
MPS1-1080-PC		2	96	23.3	48.7	49	95	1.7	12	●	2
MPS1-1080-L8C		8	172	88.6	123	126	170	2.0	12	●	2
MPS1-1080-L10C		10	193	110	145	147	192	2.0	12	□	2
MPS1-1080-L12C		12	215	131.6	167	169	214	2.0	12	●	2
MPS1-1080-L15C		15	248	164	200	202	247	2.0	12	□	2
MPS1-1080-L20C		20	303	218	255	257	302	2.0	12	□	2
MPS1-1080-L25C		25	358	272	310	312	357	2.0	12	□	2
MPS1-1090S-DIN	10.9	3	102	38.6	55	57	100	2.0	12	□	4
MPS1-1090S-DIN-C		3	102	38.6	55	57	100	2.0	12	●	2
MPS1-1090L-DIN		5	118	54.6	71	73	116	2.0	12	□	4
MPS1-1090L-DIN-C		5	118	54.6	71	73	116	2.0	12	●	2
MPS1-1090-PC		2	96	23.5	48.7	49	95	1.7	12	□	2
MPS1-1090-L8C		8	172	89.5	123	126	170	2.0	12	●	2
MPS1-1090-L10C		10	193	111	145	147	192	2.0	12	□	2
MPS1-1090-L12C		12	215	132.8	167	169	214	2.0	12	□	2
MPS1-1090-L15C		15	248	165.5	200	202	247	2.0	12	□	2
MPS1-1090-L20C		20	303	220	255	257	302	2.0	12	□	2
MPS1-1090-L25C		25	358	274.5	310	312	357	2.0	12	□	2
MPS1-1100S-DIN	11	3	102	38.5	55	57	100	2.0	12	□	4
MPS1-1100S-DIN-C		3	102	38.5	55	57	100	2.0	12	●	2
MPS1-1100L-DIN		5	118	54.5	71	73	116	2.0	12	□	4
MPS1-1100L-DIN-C		5	118	54.5	71	73	116	2.0	12	●	2
MPS1-1100-PC		2	96	23.7	48.7	49	95	1.7	12	●	2
MPS1-1100-L8C		8	172	90.3	123	126	170	2.0	12	●	2
MPS1-1100-L10C		10	194	112	145	148	192	2.0	12	□	2
MPS1-1100-L12C		12	216	134	167	170	214	2.0	12	●	2
MPS1-1100-L15C		15	249	167	200	203	247	2.0	12	●	2
MPS1-1100-L20C		20	304	222	255	258	302	2.0	12	●	2
MPS1-1100-L25C		25	359	277	310	313	357	2.0	12	●	2

# MPS1

## YEKPARE KARBÜR MATKAP

Sipariş Numarası	DC	(l/d)	OAL	LU	LCF	LH	LF	PL	DCON	DP1021	Tür
MPS1-1110S-DIN	11.1	3	102	38.4	55	57	100	2.0	12	□	4
MPS1-1110S-DIN-C		3	102	38.4	55	57	100	2.0	12	●	2
MPS1-1110L-DIN		5	118	54.4	71	73	116	2.0	12	□	4
MPS1-1110L-DIN-C		5	118	54.4	71	73	116	2.0	12	●	2
MPS1-1110-PC		2	96	23.9	48.7	51	95	1.7	12	●	2
MPS1-1110-L8C		8	178	91.1	129	132	176	2.0	12	●	2
MPS1-1110-L10C		10	201	113	152	155	199	2.0	12	□	2
MPS1-1110-L12C		12	224	135.2	175	178	222	2.0	12	●	2
MPS1-1110-L15C		15	258	168.5	209	212	256	2.0	12	●	2
MPS1-1110-L20C		20	316	224	267	270	314	2.0	12	□	2
MPS1-1110-L25C		25	373	279.5	324	327	371	2.0	12	●	2
MPS1-1120S-DIN	11.2	3	102	38.2	55	57	100	2.0	12	□	4
MPS1-1120S-DIN-C		3	102	38.2	55	57	100	2.0	12	●	2
MPS1-1120L-DIN		5	118	54.2	71	73	116	2.0	12	□	4
MPS1-1120L-DIN-C		5	118	54.2	71	73	116	2.0	12	●	2
MPS1-1120-PC		2	96	24.2	48.8	51	95	1.8	12	●	2
MPS1-1120-L8C		8	178	91.9	129	132	176	2.0	12	●	2
MPS1-1120-L10C		10	201	114	152	155	199	2.0	12	□	2
MPS1-1120-L12C		12	224	136.4	175	178	222	2.0	12	□	2
MPS1-1120-L15C		15	258	170	209	212	256	2.0	12	●	2
MPS1-1120-L20C		20	316	226	267	270	314	2.0	12	□	2
MPS1-1120-L25C		25	373	282	324	327	371	2.0	12	□	2
MPS1-1130S-DIN	11.3	3	102	38.1	55	57	99.9	2.1	12	□	4
MPS1-1130S-DIN-C		3	102	38.1	55	57	99.9	2.1	12	●	2
MPS1-1130L-DIN		5	118	54.1	71	73	115.9	2.1	12	□	4
MPS1-1130L-DIN-C		5	118	54.1	71	73	115.9	2.1	12	●	2
MPS1-1130-PC		2	96	24.4	48.8	51	95	1.8	12	□	2
MPS1-1130-L8C		8	178	92.7	129	132	176	2.1	12	●	2
MPS1-1130-L10C		10	201	115.1	152.1	155	199	2.1	12	□	2
MPS1-1130-L12C		12	224	137.7	175.1	178	222	2.1	12	□	2
MPS1-1130-L15C		15	258	171.6	209.1	212	256	2.1	12	□	2
MPS1-1130-L20C		20	316	228.1	267.1	270	314	2.1	12	□	2
MPS1-1130-L25C		25	373	284.6	324.1	327	371	2.1	12	□	2
MPS1-1140S-DIN	11.4	3	102	38.0	55	57	99.9	2.1	12	□	4
MPS1-1140S-DIN-C		3	102	38.0	55	57	99.9	2.1	12	●	2
MPS1-1140L-DIN		5	118	54.0	71	73	115.9	2.1	12	□	4
MPS1-1140L-DIN-C		5	118	54.0	71	73	115.9	2.1	12	●	2
MPS1-1140-PC		2	96	24.6	48.8	51	95	1.8	12	□	2
MPS1-1140-L8C		8	178	93.6	129	132	176	2.1	12	●	2
MPS1-1140-L10C		10	201	116.1	152.1	155	199	2.1	12	□	2
MPS1-1140-L12C		12	224	138.9	175.1	178	222	2.1	12	□	2
MPS1-1140-L15C		15	258	173.1	209.1	212	256	2.1	12	□	2
MPS1-1140-L20C		20	316	230.1	267.1	270	314	2.1	12	□	2
MPS1-1140-L25C		25	373	287.1	324.1	327	371	2.1	12	□	2



# MPS1

## YEKPARE KARBÜR MATKAP

Sipariş Numarası	DC	(l/d)	OAL	LU	LCF	LH	LF	PL	DCON	DP1021	Tür
MPS1-1150S-DIN		3	102	37.8	55	57	99.9	2.1	12	□	4
MPS1-1150S-DIN-C		3	102	37.8	55	57	99.9	2.1	12	●	2
MPS1-1150L-DIN		5	118	53.8	71	73	115.9	2.1	12	□	4
MPS1-1150L-DIN-C		5	118	53.8	71	73	115.9	2.1	12	●	2
MPS1-1150-PC		2	96	24.8	48.8	51	95	1.8	12	●	2
MPS1-1150-L8C	11.5	8	178	94.4	129	132	176	2.1	12	●	2
MPS1-1150-L10C		10	201	117.1	152.1	155	199	2.1	12	□	2
MPS1-1150-L12C		12	224	140.1	175.1	178	222	2.1	12	●	2
MPS1-1150-L15C		15	258	174.6	209.1	212	256	2.1	12	●	2
MPS1-1150-L20C		20	316	232.1	267.1	270	314	2.1	12	●	2
MPS1-1150-L25C		25	373	289.6	324.1	327	371	2.1	12	●	2
MPS1-1160S-DIN		3	102	37.7	55	57	99.9	2.1	12	□	4
MPS1-1160S-DIN-C		3	102	37.7	55	57	99.9	2.1	12	●	2
MPS1-1160L-DIN		5	118	53.7	71	73	115.9	2.1	12	□	4
MPS1-1160L-DIN-C		5	118	53.7	71	73	115.9	2.1	12	●	2
MPS1-1160-PC		2	96	25	48.8	48	95	1.8	12	□	2
MPS1-1160-L8C	11.6	8	183	95.2	134	137	181	2.1	12	●	2
MPS1-1160-L10C		10	207	118.1	158.1	161	205	2.1	12	□	2
MPS1-1160-L12C		12	231	141.3	182.1	185	229	2.1	12	□	2
MPS1-1160-L15C		15	267	176.1	218.1	221	265	2.1	12	□	2
MPS1-1160-L20C		20	327	234.1	278.1	281	325	2.1	12	□	2
MPS1-1160-L25C		25	387	292.1	338.1	341	385	2.1	12	□	2
MPS1-1170S-DIN		3	102	37.6	55	57	99.9	2.1	12	□	4
MPS1-1170S-DIN-C		3	102	37.6	55	57	99.9	2.1	12	●	2
MPS1-1170L-DIN		5	118	53.6	71	73	115.9	2.1	12	□	4
MPS1-1170L-DIN-C		5	118	53.6	71	73	115.9	2.1	12	●	2
MPS1-1170-PC		2	96	25.2	48.8	48	95	1.8	12	●	2
MPS1-1170-L8C	11.7	8	183	96.0	134	137	181	2.1	12	●	2
MPS1-1170-L10C		10	207	119.1	158.1	161	205	2.1	12	□	2
MPS1-1170-L12C		12	231	142.5	182.1	185	229	2.1	12	●	2
MPS1-1170-L15C		15	267	177.6	218.1	221	265	2.1	12	●	2
MPS1-1170-L20C		20	327	236.1	278.1	281	325	2.1	12	□	2
MPS1-1170-L25C		25	387	294.6	338.1	341	385	2.1	12	□	2
MPS1-1180S-DIN		3	102	37.4	55	57	99.9	2.1	12	□	4
MPS1-1180S-DIN-C		3	102	37.4	55	57	99.9	2.1	12	●	2
MPS1-1180L-DIN		5	118	53.4	71	73	115.9	2.1	12	□	4
MPS1-1180L-DIN-C		5	118	53.4	71	73	115.9	2.1	12	●	2
MPS1-1180-PC		2	96	25.5	48.9	48	95	1.9	12	●	2
MPS1-1180-L8C	11.8	8	183	96.8	134	137	181	2.1	12	●	2
MPS1-1180-L10C		10	207	120.1	158.1	161	205	2.1	12	□	2
MPS1-1180-L12C		12	231	143.7	182.1	185	229	2.1	12	●	2
MPS1-1180-L15C		15	267	179.1	218.1	221	265	2.1	12	●	2
MPS1-1180-L20C		20	327	238.1	278.1	281	325	2.1	12	□	2
MPS1-1180-L25C		25	387	297.1	338.1	341	385	2.1	12	□	2

# MPS1

## YEKPARE KARBÜR MATKAP

Sipariş Numarası	DC	(l/d)	OAL	LU	LCF	LH	LF	PL	DCON	DP1021	Tür
MPS1-1190S-DIN	11.9	3	102	37.3	55	57	99.8	2.2	12	□	4
MPS1-1190S-DIN-C		3	102	37.3	55	57	99.8	2.2	12	●	2
MPS1-1190L-DIN		5	118	53.3	71	73	115.8	2.2	12	□	4
MPS1-1190L-DIN-C		5	118	53.3	71	73	115.8	2.2	12	●	2
MPS1-1190-PC		2	96	25.7	48.9	48	95	1.9	12	□	2
MPS1-1190-L8C		8	183	97.7	134	137	181	2.2	12	●	2
MPS1-1190-L10C		10	207	121.2	158.2	161	205	2.2	12	□	2
MPS1-1190-L12C		12	231	145	182.2	185	229	2.2	12	□	2
MPS1-1190-L15C		15	267	180.7	218.2	221	265	2.2	12	□	2
MPS1-1190-L20C		20	327	240.2	278.2	281	325	2.2	12	□	2
MPS1-1190-L25C		25	387	299.7	338.2	341	385	2.2	12	□	2
MPS1-1200S-DIN	12	3	102	37.2	55	57	99.8	2.2	12	□	4
MPS1-1200S-DIN-C		3	102	37.2	55	57	99.8	2.2	12	●	2
MPS1-1200L-DIN		5	118	53.2	71	73	115.8	2.2	12	□	4
MPS1-1200L-DIN-C		5	118	53.2	71	73	115.8	2.2	12	●	2
MPS1-1200-PC		2	96	25.9	48.9	48	95	1.9	12	●	2
MPS1-1200-L8C		8	183	98.5	134	137	181	2.2	12	●	2
MPS1-1200-L10C		10	207	122.2	158.2	161	205	2.2	12	□	2
MPS1-1200-L12C		12	231	146.2	182.2	185	229	2.2	12	●	2
MPS1-1200-L15C		15	267	182.2	218.2	221	265	2.2	12	●	2
MPS1-1200-L20C		20	327	242.2	278.2	281	325	2.2	12	●	2
MPS1-1200-L25C		25	387	302.2	338.2	341	385	2.2	12	●	2
MPS1-1205S-DIN	12.05	3	107	42.1	60	62	104.8	2.2	14	□	4
MPS1-1205S-DIN-C		3	107	42.1	60	62	104.8	2.2	14	●	2
MPS1-1205L-DIN		5	124	59.1	77	79	121.8	2.2	14	□	4
MPS1-1205L-DIN-C		5	124	59.1	77	79	121.8	2.2	14	●	2
MPS1-1210S-DIN	12.1	3	107	42.1	60	62	104.8	2.2	14	□	4
MPS1-1210S-DIN-C		3	107	42.1	60	62	104.8	2.2	14	●	2
MPS1-1210L-DIN		5	124	59.1	77	79	121.8	2.2	14	□	4
MPS1-1210L-DIN-C		5	124	59.1	77	79	121.8	2.2	14	●	2
MPS1-1210-PC		2	103	26.1	52.9	55	102	1.9	14	●	2
MPS1-1210-L8C		8	190	99.3	140	144	187	2.2	14	●	2
MPS1-1210-L10C		10	214	123.2	165.2	168	212	2.2	14	□	2
MPS1-1210-L12C		12	239	147.4	190.2	193	237	2.2	14	●	2
MPS1-1210-L15C		15	276	183.7	227.2	230	274	2.2	14	●	2
MPS1-1210-L20C		20	339	244.2	290.2	293	337	2.2	14	□	2
MPS1-1220S-DIN		12.2	3	107	41.9	60	62	104.8	2.2	14	□
MPS1-1220S-DIN-C	3		107	41.9	60	62	104.8	2.2	14	●	2
MPS1-1220L-DIN	5		124	58.9	77	79	121.8	2.2	14	□	4
MPS1-1220L-DIN-C	5		124	58.9	77	79	121.8	2.2	14	●	2
MPS1-1220-PC	2		103	26.3	52.9	55	102	1.9	14	●	2
MPS1-1220-L8C	8		190	100.1	140	144	187	2.2	14	●	2
MPS1-1220-L10C	10		214	124.2	165.2	168	212	2.2	14	□	2
MPS1-1220-L12C	12		239	148.6	190.2	193	237	2.2	14	●	2
MPS1-1220-L15C	15		276	185.2	227.2	230	274	2.2	14	●	2
MPS1-1220-L20C	20		339	246.2	290.2	293	337	2.2	14	□	2

# MPS1

## YEKPARE KARBÜR MATKAP

Sipariş Numarası	DC	(l/d)	OAL	LU	LCF	LH	LF	PL	DCON	DP1021	Tür
MPS1-1230S-DIN	12.3	3	107	41.8	60	62	104.8	2.2	14	□	4
MPS1-1230S-DIN-C		3	107	41.8	60	62	104.8	2.2	14	●	2
MPS1-1230L-DIN		5	124	58.8	77	79	121.8	2.2	14	□	4
MPS1-1230L-DIN-C		5	124	58.8	77	79	121.8	2.2	14	●	2
MPS1-1230-PC		2	103	26.5	52.9	55	102	1.9	14	□	2
MPS1-1230-L8C		8	190	100.9	140	144	187	2.2	14	●	2
MPS1-1230-L10C		10	214	125.2	165.2	168	212	2.2	14	□	2
MPS1-1230-L12C		12	239	149.8	190.2	193	237	2.2	14	□	2
MPS1-1230-L15C		15	276	186.7	227.2	230	274	2.2	14	□	2
MPS1-1230-L20C		20	339	248.2	290.2	293	337	2.2	14	□	2
MPS1-1240S-DIN	12.4	3	107	41.7	60	62	104.7	2.3	14	□	4
MPS1-1240S-DIN-C		3	107	41.7	60	62	104.7	2.3	14	●	2
MPS1-1240L-DIN		5	124	58.7	77	79	121.7	2.3	14	□	4
MPS1-1240L-DIN-C		5	124	58.7	77	79	121.7	2.3	14	●	2
MPS1-1240-PC		2	103	26.8	53	55	102	2.0	14	□	2
MPS1-1240-L8C		8	190	101.8	140	144	187	2.3	14	●	2
MPS1-1240-L10C		10	214	126.3	165.3	168	212	2.3	14	□	2
MPS1-1240-L12C		12	239	151.1	190.3	193	237	2.3	14	□	2
MPS1-1240-L15C		15	276	188.3	227.3	230	274	2.3	14	□	2
MPS1-1240-L20C		20	339	250.3	290.3	293	337	2.3	14	□	2
MPS1-1250S-DIN	12.5	3	107	41.5	60	62	104.7	2.3	14	□	4
MPS1-1250S-DIN-C		3	107	41.5	60	62	104.7	2.3	14	●	2
MPS1-1250L-DIN		5	124	58.5	77	79	121.7	2.3	14	□	4
MPS1-1250L-DIN-C		5	124	58.5	77	79	121.7	2.3	14	●	2
MPS1-1250-PC		2	103	27	53	55	102	2.0	14	●	2
MPS1-1250-L8C		8	190	102.6	140	144	187	2.3	14	●	2
MPS1-1250-L10C		10	214	127.3	165.3	168	212	2.3	14	□	2
MPS1-1250-L12C		12	239	152.3	190.3	193	237	2.3	14	●	2
MPS1-1250-L15C		15	276	189.8	227.3	230	274	2.3	14	●	2
MPS1-1250-L20C		20	339	252.3	290.3	293	337	2.3	14	□	2
MPS1-1260S-DIN	12.6	3	107	41.4	60	62	104.7	2.3	14	□	4
MPS1-1260S-DIN-C		3	107	41.4	60	62	104.7	2.3	14	●	2
MPS1-1260L-DIN		5	124	58.4	77	79	121.7	2.3	14	□	4
MPS1-1260L-DIN-C		5	124	58.4	77	79	121.7	2.3	14	●	2
MPS1-1260-PC		2	103	27.2	53	54	102	2.0	14	□	2
MPS1-1260-L8C		8	195	103.4	145	149	192	2.3	14	●	2
MPS1-1260-L10C		10	220	128.3	171.3	174	218	2.3	14	□	2
MPS1-1260-L12C		12	246	153.5	197.3	200	244	2.3	14	□	2
MPS1-1260-L15C		15	285	191.3	236.3	239	283	2.3	14	□	2
MPS1-1260-L20C		20	350	254.3	301.3	304	348	2.3	14	□	2

# MPS1

## YEKPARE KARBÜR MATKAP

Sipariş Numarası	DC	(l/d)	OAL	LU	LCF	LH	LF	PL	DCON	DP1021	Tür
MPS1-1270S-DIN	12.7	3	107	41.3	60	62	104.7	2.3	14	□	4
MPS1-1270S-DIN-C		3	107	41.3	60	62	104.7	2.3	14	●	2
MPS1-1270L-DIN		5	124	58.3	77	79	121.7	2.3	14	□	4
MPS1-1270L-DIN-C		5	124	58.3	77	79	121.7	2.3	14	●	2
MPS1-1270-PC		2	104	27.4	53	55	102	2.0	14	●	2
MPS1-1270-L8C		8	195	104.2	145	149	192	2.3	14	●	2
MPS1-1270-L10C		10	220	129.3	171.3	174	218	2.3	14	□	2
MPS1-1270-L12C		12	246	154.7	197.3	200	244	2.3	14	●	2
MPS1-1270-L15C		15	285	192.8	236.3	239	283	2.3	14	□	2
MPS1-1270-L20C		20	350	256.3	301.3	304	348	2.3	14	□	2
MPS1-1280S-DIN	12.8	3	107	41.1	60	62	104.7	2.3	14	□	4
MPS1-1280S-DIN-C		3	107	41.1	60	62	104.7	2.3	14	●	2
MPS1-1280L-DIN		5	124	58.1	77	79	121.7	2.3	14	□	4
MPS1-1280L-DIN-C		5	124	58.1	77	79	121.7	2.3	14	●	2
MPS1-1280-PC		2	104	27.6	53	55	102	2.0	14	●	2
MPS1-1280-L8C		8	195	105.1	145	149	192	2.3	14	●	2
MPS1-1280-L10C		10	220	130.3	171.3	174	218	2.3	14	□	2
MPS1-1280-L12C		12	246	155.9	197.3	200	244	2.3	14	●	2
MPS1-1280-L15C		15	285	194.3	236.3	239	283	2.3	14	□	2
MPS1-1280-L20C		20	350	258.3	301.3	304	348	2.3	14	□	2
MPS1-1290S-DIN	12.9	3	107	41.0	60	62	104.7	2.3	14	□	4
MPS1-1290S-DIN-C		3	107	41.0	60	62	104.7	2.3	14	●	2
MPS1-1290L-DIN		5	124	58.0	77	79	121.7	2.3	14	□	4
MPS1-1290L-DIN-C		5	124	58.0	77	79	121.7	2.3	14	●	2
MPS1-1290-PC		2	104	27.8	53	55	102	2.0	14	□	2
MPS1-1290-L8C		8	195	105.9	145	149	192	2.3	14	●	2
MPS1-1290-L10C		10	220	131.3	171.3	174	218	2.3	14	□	2
MPS1-1290-L12C		12	246	157.1	197.3	200	244	2.3	14	□	2
MPS1-1290-L15C		15	285	195.8	236.3	239	283	2.3	14	□	2
MPS1-1290-L20C		20	350	260.3	301.3	304	348	2.3	14	□	2
MPS1-1300S-DIN	13	3	107	40.9	60	62	104.6	2.4	14	□	4
MPS1-1300S-DIN-C		3	107	40.9	60	62	104.6	2.4	14	●	2
MPS1-1300L-DIN		5	124	57.9	77	79	121.6	2.4	14	□	4
MPS1-1300L-DIN-C		5	124	57.9	77	79	121.6	2.4	14	●	2
MPS1-1300-PC		2	104	28	53	55	102	2.0	14	●	2
MPS1-1300-L8C		8	195	106.7	145	149	192	2.4	14	●	2
MPS1-1300-L10C		10	220	132.4	171.4	174	218	2.4	14	□	2
MPS1-1300-L12C		12	246	158.4	197.4	200	244	2.4	14	●	2
MPS1-1300-L15C		15	285	197.4	236.4	239	283	2.4	14	●	2
MPS1-1300-L20C		20	350	262.4	301.4	304	348	2.4	14	●	2

# MPS1

## YEKPARE KARBÜR MATKAP

Sipariş Numarası	DC	(l/d)	OAL	LU	LCF	LH	LF	PL	DCON	DP1021	Tür
MPS1-1310S-DIN	13.1	3	107	40.7	60	62	104.6	2.4	14	□	4
MPS1-1310S-DIN-C		3	107	40.7	60	62	104.6	2.4	14	●	2
MPS1-1310L-DIN		5	124	57.7	77	79	121.6	2.4	14	□	4
MPS1-1310L-DIN-C		5	124	57.7	77	79	121.6	2.4	14	●	2
MPS1-1310-PC		2	109	28.3	56.1	59	107	2.1	14	□	2
MPS1-1310-L8C		8	201	107.5	151	155	198	2.4	14	●	2
MPS1-1310-L10C		10	227	133.4	178.4	181	225	2.4	14	□	2
MPS1-1310-L12C		12	254	159.6	205.4	208	252	2.4	14	□	2
MPS1-1310-L15C		15	294	198.9	245.4	248	292	2.4	14	□	2
MPS1-1310-L20C		20	362	264.4	313.4	316	360	2.4	14	□	2
MPS1-1320S-DIN	13.2	3	107	40.6	60	62	104.6	2.4	14	□	4
MPS1-1320S-DIN-C		3	107	40.6	60	62	104.6	2.4	14	●	2
MPS1-1320L-DIN		5	124	57.6	77	79	121.6	2.4	14	□	4
MPS1-1320L-DIN-C		5	124	57.6	77	79	121.6	2.4	14	●	2
MPS1-1320-PC		2	109	28.5	56.1	59	107	2.1	14	●	2
MPS1-1320-L8C		8	201	108.3	151	155	198	2.4	14	●	2
MPS1-1320-L10C		10	227	134.4	178.4	181	225	2.4	14	□	2
MPS1-1320-L12C		12	254	160.8	205.4	208	252	2.4	14	●	2
MPS1-1320-L15C		15	294	200.4	245.4	248	292	2.4	14	□	2
MPS1-1320-L20C		20	362	266.4	313.4	316	360	2.4	14	□	2
MPS1-1330S-DIN	13.3	3	107	40.5	60	62	104.6	2.4	14	□	4
MPS1-1330S-DIN-C		3	107	40.5	60	62	104.6	2.4	14	●	2
MPS1-1330L-DIN		5	124	57.5	77	79	121.6	2.4	14	□	4
MPS1-1330L-DIN-C		5	124	57.5	77	79	121.6	2.4	14	●	2
MPS1-1330-PC		2	109	28.7	56.1	59	107	2.1	14	□	2
MPS1-1330-L8C		8	201	109.2	151	155	198	2.4	14	●	2
MPS1-1330-L10C		10	227	135.4	178.4	181	225	2.4	14	□	2
MPS1-1330-L12C		12	254	162	205.4	208	252	2.4	14	□	2
MPS1-1330-L15C		15	294	201.9	245.4	248	292	2.4	14	□	2
MPS1-1330-L20C		20	362	268.4	313.4	316	360	2.4	14	□	2
MPS1-1340S-DIN	13.4	3	107	40.3	60	62	104.6	2.4	14	□	4
MPS1-1340S-DIN-C		3	107	40.3	60	62	104.6	2.4	14	●	2
MPS1-1340L-DIN		5	124	57.3	77	79	121.6	2.4	14	□	4
MPS1-1340L-DIN-C		5	124	57.3	77	79	121.6	2.4	14	●	2
MPS1-1340-PC		2	109	28.9	56.1	59	107	2.1	14	□	2
MPS1-1340-L8C		8	201	110.0	151	155	198	2.4	14	●	2
MPS1-1340-L10C		10	227	136.4	178.4	181	225	2.4	14	□	2
MPS1-1340-L12C		12	254	163.2	205.4	208	252	2.4	14	□	2
MPS1-1340-L15C		15	294	203.4	245.4	248	292	2.4	14	□	2
MPS1-1340-L20C		20	362	270.4	313.4	316	360	2.4	14	□	2

# MPS1

## YEKPARE KARBÜR MATKAP

Sipariş Numarası	DC	(l/d)	OAL	LU	LCF	LH	LF	PL	DCON	DP1021	Tür
MPS1-1350S-DIN	13.5	3	107	40.2	60	62	104.5	2.5	14	□	4
MPS1-1350S-DIN-C		3	107	40.2	60	62	104.5	2.5	14	●	2
MPS1-1350L-DIN		5	124	57.2	77	79	121.5	2.5	14	□	4
MPS1-1350L-DIN-C		5	124	57.2	77	79	121.5	2.5	14	●	2
MPS1-1350-PC		2	109	29.1	56.1	59	107	2.1	14	●	2
MPS1-1350-L8C		8	201	110.8	151	155	198	2.5	14	●	2
MPS1-1350-L10C		10	227	137.5	178.5	181	225	2.5	14	□	2
MPS1-1350-L12C		12	254	164.5	205.5	208	252	2.5	14	●	2
MPS1-1350-L15C		15	294	205	245.5	248	292	2.5	14	□	2
MPS1-1350-L20C		20	362	272.5	313.5	316	360	2.5	14	□	2
MPS1-1360S-DIN	13.6	3	107	40.1	60	62	104.5	2.5	14	□	4
MPS1-1360S-DIN-C		3	107	40.1	60	62	104.5	2.5	14	●	2
MPS1-1360L-DIN		5	124	57.1	77	79	121.5	2.5	14	□	4
MPS1-1360L-DIN-C		5	124	57.1	77	79	121.5	2.5	14	●	2
MPS1-1360-PC		2	109	29.3	56.1	56	107	2.1	14	□	2
MPS1-1360-L8C		8	206	111.6	156	160	203	2.5	14	●	2
MPS1-1360-L10C		10	233	138.5	184.5	187	231	2.5	14	□	2
MPS1-1360-L12C		12	261	165.7	212.5	215	259	2.5	14	□	2
MPS1-1360-L15C		15	303	206.5	254.5	257	301	2.5	14	□	2
MPS1-1360-L20C		20	373	274.5	324.5	327	371	2.5	14	□	2
MPS1-1370S-DIN	13.7	3	107	39.9	60	62	104.5	2.5	14	□	4
MPS1-1370S-DIN-C		3	107	39.9	60	62	104.5	2.5	14	●	2
MPS1-1370L-DIN		5	124	56.9	77	79	121.5	2.5	14	□	4
MPS1-1370L-DIN-C		5	124	56.9	77	79	121.5	2.5	14	●	2
MPS1-1370-PC		2	109	29.6	56.2	56	107	2.2	14	□	2
MPS1-1370-L8C		8	206	112.4	156	160	203	2.5	14	●	2
MPS1-1370-L10C		10	233	139.5	184.5	187	231	2.5	14	□	2
MPS1-1370-L12C		12	261	166.9	212.5	215	259	2.5	14	□	2
MPS1-1370-L15C		15	303	208	254.5	257	301	2.5	14	□	2
MPS1-1370-L20C		20	373	276.5	324.5	327	371	2.5	14	□	2
MPS1-1380S-DIN	13.8	3	107	39.8	60	62	104.5	2.5	14	□	4
MPS1-1380S-DIN-C		3	107	39.8	60	62	104.5	2.5	14	●	2
MPS1-1380L-DIN		5	124	56.8	77	79	121.5	2.5	14	□	4
MPS1-1380L-DIN-C		5	124	56.8	77	79	121.5	2.5	14	●	2
MPS1-1380-PC		2	109	29.8	56.2	56	107	2.2	14	□	2
MPS1-1380-L8C		8	206	113.3	156	160	203	2.5	14	●	2
MPS1-1380-L10C		10	233	140.5	184.5	187	231	2.5	14	□	2
MPS1-1380-L12C		12	261	168.1	212.5	215	259	2.5	14	□	2
MPS1-1380-L15C		15	303	209.5	254.5	257	301	2.5	14	□	2
MPS1-1380-L20C		20	373	278.5	324.5	327	371	2.5	14	□	2

# MPS1

## YEKPARE KARBÜR MATKAP

Sipariş Numarası	DC	(l/d)	OAL	LU	LCF	LH	LF	PL	DCON	DP1021	Tür
MPS1-1390S-DIN	13.9	3	107	39.7	60	62	104.5	2.5	14	□	4
MPS1-1390S-DIN-C		3	107	39.7	60	62	104.5	2.5	14	●	2
MPS1-1390L-DIN		5	124	56.7	77	79	121.5	2.5	14	□	4
MPS1-1390L-DIN-C		5	124	56.7	77	79	121.5	2.5	14	●	2
MPS1-1390-PC		2	109	30	56.2	56	107	2.2	14	□	2
MPS1-1390-L8C		8	206	114.1	156	160	203	2.5	14	●	2
MPS1-1390-L10C		10	233	141.5	184.5	187	231	2.5	14	□	2
MPS1-1390-L12C		12	261	169.3	212.5	215	259	2.5	14	□	2
MPS1-1390-L15C		15	303	211	254.5	257	301	2.5	14	□	2
MPS1-1390-L20C		20	373	280.5	324.5	327	371	2.5	14	□	2
MPS1-1400S-DIN	14	3	107	39.5	60	62	104.5	2.5	14	□	4
MPS1-1400S-DIN-C		3	107	39.5	60	62	104.5	2.5	14	●	2
MPS1-1400L-DIN		5	124	56.5	77	79	121.5	2.5	14	□	4
MPS1-1400L-DIN-C		5	124	56.5	77	79	121.5	2.5	14	●	2
MPS1-1400-PC		2	109	30.2	56.2	56	107	2.2	14	●	2
MPS1-1400-L8C		8	206	114.9	156	160	203	2.5	14	●	2
MPS1-1400-L10C		10	233	142.5	184.5	187	231	2.5	14	□	2
MPS1-1400-L12C		12	261	170.5	212.5	215	259	2.5	14	●	2
MPS1-1400-L15C		15	303	212.5	254.5	257	301	2.5	14	●	2
MPS1-1400-L20C		20	373	282.5	324.5	327	371	2.5	14	●	2
MPS1-1420S-DIN	14.2	3	114	43.3	64	66	111.4	2.6	16	□	4
MPS1-1420S-DIN-C		3	114	43.3	64	66	111.4	2.6	16	●	2
MPS1-1420L-DIN		5	132	61.3	82	84	129.4	2.6	16	□	4
MPS1-1420L-DIN-C		5	132	61.3	82	84	129.4	2.6	16	●	2
MPS1-1450S-DIN	14.5	3	114	42.9	64	66	111.4	2.6	16	□	4
MPS1-1450S-DIN-C		3	114	42.9	64	66	111.4	2.6	16	●	2
MPS1-1450L-DIN		5	132	60.9	82	84	129.4	2.6	16	□	4
MPS1-1450L-DIN-C		5	132	60.9	82	84	129.4	2.6	16	●	2
MPS1-1500S-DIN	15	3	114	42.2	64	66	111.3	2.7	16	□	4
MPS1-1500S-DIN-C		3	114	42.2	64	66	111.3	2.7	16	●	2
MPS1-1500L-DIN		5	132	60.2	82	84	129.3	2.7	16	□	4
MPS1-1500L-DIN-C		5	132	60.2	82	84	129.3	2.7	16	●	2
MPS1-1550S-DIN	15.5	3	115	41.6	65	67	112.2	2.8	16	□	4
MPS1-1550S-DIN-C		3	115	41.6	65	67	112.2	2.8	16	●	2
MPS1-1550L-DIN		5	133	59.6	83	85	130.2	2.8	16	□	4
MPS1-1550L-DIN-C	5	133	59.6	83	85	130.2	2.8	16	●	2	
MPS1-1600S-DIN	16	3	115	40.9	65	67	112.1	2.9	16	□	4
MPS1-1600S-DIN-C		3	115	40.9	65	67	112.1	2.9	16	●	2
MPS1-1600L-DIN		5	133	58.9	83	85	130.1	2.9	16	□	4
MPS1-1600L-DIN-C		5	133	58.9	83	85	130.1	2.9	16	●	2
MPS1-1650S-DIN	16.5	3	123	48.3	73	75	120	3.0	18	□	4
MPS1-1650S-DIN-C		3	123	48.3	73	75	120	3.0	18	●	2
MPS1-1650L-DIN		5	143	68.3	93	95	140	3.0	18	□	4
MPS1-1650L-DIN-C		5	143	68.3	93	95	140	3.0	18	●	2
MPS1-1700S-DIN	17	3	123	47.6	73	75	119.9	3.1	18	□	4
MPS1-1700S-DIN-C		3	123	47.6	73	75	119.9	3.1	18	●	2
MPS1-1700L-DIN		5	143	67.6	93	95	139.9	3.1	18	□	4
MPS1-1700L-DIN-C		5	143	67.6	93	95	139.9	3.1	18	●	2

# MPS1

## YEKPARE KARBÜR MATKAP

Sipariş Numarası	DC	(l/d)	OAL	LU	LCF	LH	LF	PL	DCON	DP1021	Tür
MPS1-1750S-DIN	17.5	3	123	46.9	73	75	119.8	3.2	18	□	4
MPS1-1750S-DIN-C		3	123	46.9	73	75	119.8	3.2	18	●	2
MPS1-1750L-DIN		5	143	66.9	93	95	139.8	3.2	18	□	4
MPS1-1750L-DIN-C		5	143	66.9	93	95	139.8	3.2	18	●	2
MPS1-1800S-DIN	18	3	123	46.3	73	75	119.7	3.3	18	□	4
MPS1-1800S-DIN-C		3	123	46.3	73	75	119.7	3.3	18	●	2
MPS1-1800L-DIN		5	143	66.3	93	95	139.7	3.3	18	□	4
MPS1-1800L-DIN-C		5	143	66.3	93	95	139.7	3.3	18	●	2
MPS1-1850S-DIN	18.5	3	131	51.6	79	81	127.6	3.4	20	□	4
MPS1-1850S-DIN-C		3	131	51.6	79	81	127.6	3.4	20	●	2
MPS1-1850L-DIN		5	153	73.6	101	103	149.6	3.4	20	□	4
MPS1-1850L-DIN-C		5	153	73.6	101	103	149.6	3.4	20	●	2
MPS1-1900S-DIN	19	3	131	51.0	79	81	127.5	3.5	20	□	4
MPS1-1900S-DIN-C		3	131	51.0	79	81	127.5	3.5	20	●	2
MPS1-1900L-DIN		5	153	73.0	101	103	149.5	3.5	20	□	4
MPS1-1900L-DIN-C		5	153	73.0	101	103	149.5	3.5	20	●	2
MPS1-1950S-DIN	19.5	3	131	50.3	79	81	127.5	3.5	20	□	4
MPS1-1950S-DIN-C		3	131	50.3	79	81	127.5	3.5	20	●	2
MPS1-1950L-DIN		5	153	72.3	101	103	149.5	3.5	20	□	4
MPS1-1950L-DIN-C		5	153	72.3	101	103	149.5	3.5	20	●	2
MPS1-2000S-DIN	20	3	131	49.6	79	81	127.4	3.6	20	□	4
MPS1-2000S-DIN-C		3	131	49.6	79	81	127.4	3.6	20	●	2
MPS1-2000L-DIN		5	153	71.6	101	103	149.4	3.6	20	□	4
MPS1-2000L-DIN-C		5	153	71.6	101	103	149.4	3.6	20	●	2



# MPS1

## ÖNERİLEN KESME KOŞULLARI

Malzeme	Özellikler	DC	L x DC	Vc	f
Çelik	<180HB	3	3-8	100 ( 60-150)	0.15 (0.10-0.20)
			10-25	90 ( 40-110)	0.17 (0.10-0.24)
			30-40	75 ( 40- 95)	0.14 (0.08-0.19)
		4	3-8	120 ( 70-170)	0.19 (0.12-0.25)
			10-25	90 ( 40-110)	0.20 (0.12-0.30)
			30-40	75 ( 40- 95)	0.16 (0.10-0.24)
		5	3-8	130 ( 80-190)	0.23 (0.15-0.30)
			10-25	90 ( 40-110)	0.25 (0.15-0.35)
			30-40	75 ( 40- 95)	0.20 (0.12-0.28)
		6	3-8	140 ( 90-210)	0.27 (0.18-0.35)
			10-25	110 ( 70-120)	0.27 (0.17-0.37)
			30-40	90 ( 40-110)	0.22 (0.14-0.30)
		8	3-8	160 (100-240)	0.30 (0.20-0.40)
			10-25	110 ( 70-120)	0.30 (0.20-0.40)
			30-40	90 ( 40-110)	0.24 (0.16-0.32)
		10	3-8	170 (100-250)	0.33 (0.20-0.45)
			10-25	110 ( 70-120)	0.32 (0.22-0.42)
			30-40	90 ( 40-110)	0.26 (0.18-0.34)
		12	3-8	180 (100-250)	0.35 (0.20-0.50)
			10-25	130 ( 90-150)	0.34 (0.24-0.44)
			30-40	105 ( 55-125)	0.27 (0.19-0.35)
		16	3-8	180 (100-250)	0.38 (0.20-0.55)
			10-25	130 ( 90-150)	0.36 (0.26-0.46)
		20	3-8	180 (100-250)	0.40 (0.20-0.60)
Karbon Çelik, Alaşım Çelik	180-250HB	3	3-8	90 ( 60-140)	0.15 (0.10-0.19)
			10-25	90 ( 40-110)	0.17 (0.10-0.24)
			30-40	75 ( 40- 85)	0.14 (0.08-0.19)
		4	3-8	100 ( 70-160)	0.18 (0.12-0.24)
			10-25	90 ( 40-110)	0.20 (0.12-0.30)
			30-40	75 ( 40- 85)	0.16 (0.10-0.24)
		5	3-8	110 ( 80-180)	0.22 (0.15-0.29)
			10-25	90 ( 40-110)	0.25 (0.15-0.35)
			30-40	75 ( 40- 85)	0.20 (0.12-0.28)
		6	3-8	120 ( 90-190)	0.26 (0.18-0.33)
			10-25	100 ( 60-110)	0.24 (0.15-0.33)
			30-40	80 ( 40- 90)	0.22 (0.14-0.30)
		8	3-8	140 (100-220)	0.29 (0.20-0.38)
			10-25	100 ( 60-110)	0.30 (0.20-0.40)
			30-40	80 ( 40- 90)	0.24 (0.16-0.32)
		10	3-8	150 (100-230)	0.32 (0.20-0.43)
			10-25	100 ( 60-110)	0.32 (0.22-0.42)
			30-40	80 ( 40- 90)	0.26 (0.18-0.34)
		12	3-8	160 (100-230)	0.34 (0.20-0.48)
			10-25	120 ( 80-140)	0.34 (0.24-0.44)
			30-40	95 ( 55-105)	0.27 (0.19-0.35)
		16	3-8	160 (100-230)	0.36 (0.20-0.52)
			10-25	120 ( 80-140)	0.36 (0.26-0.46)
		20	3-8	160 (100-230)	0.39 (0.20-0.57)

# MPS1

Malzeme	Özellikler	DC	L x DC	Vc	f
P Karbon Çelik, Alaşım Çelik	280-350 HB	3	3-8	80 ( 50-110)	0.12 (0.10-0.14)
			10-25	80 ( 40- 90)	0.15 (0.09-0.22)
			30-40	65 ( 40- 75)	0.15 (0.07-0.18)
		4	3-8	90 ( 60-120)	0.15 (0.12-0.18)
			10-25	80 ( 40- 90)	0.18 (0.11-0.27)
			30-40	65 ( 40- 75)	0.18 (0.09-0.22)
		5	3-8	90 ( 70-140)	0.19 (0.15-0.22)
			10-25	80 ( 40- 90)	0.22 (0.14-0.32)
			30-40	65 ( 40- 75)	0.22 (0.11-0.26)
		6	3-8	100 ( 80-150)	0.22 (0.18-0.25)
			10-25	90 ( 40-110)	0.24 (0.15-0.33)
			30-40	75 ( 40- 85)	0.24 (0.12-0.26)
		8	3-8	120 ( 90-170)	0.24 (0.20-0.27)
			10-25	90 ( 40-110)	0.27 (0.18-0.36)
			30-40	75 ( 40- 85)	0.27 (0.14-0.29)
		10	3-8	130 ( 90-180)	0.25 (0.20-0.30)
			10-25	90 ( 40-110)	0.29 (0.20-0.38)
			30-40	75 ( 40- 95)	0.29 (0.16-0.30)
		12	3-8	140 ( 90-180)	0.27 (0.20-0.34)
			10-25	100 ( 60-110)	0.30 (0.22-0.40)
30-40	80 ( 40-100)		0.30 (0.18-0.32)		
16	3-8	140 ( 90-180)	0.28 (0.20-0.36)		
	10-25	100 ( 60-110)	0.32 (0.23-0.41)		
20	3-8	140 ( 90-180)	0.30 (0.20-0.40)		
M Paslanmaz Çelik		3	3-8	40 ( 20- 50)	0.08 (0.06-0.12)
			10-25	40 ( 20- 60)	0.07 (0.05-0.09)
			30-40	30 ( 20- 50)	0.06 (0.04-0.07)
		4	3-8	40 ( 30- 50)	0.09 (0.07-0.13)
			10-25	40 ( 20- 60)	0.08 (0.06-0.10)
			30-40	30 ( 20- 50)	0.06 (0.05-0.08)
		5	3-8	40 ( 30- 50)	0.11 (0.08-0.16)
			10-25	40 ( 20- 60)	0.10 (0.07-0.12)
			30-40	30 ( 20- 50)	0.08 (0.06-0.10)
		6	3-8	50 ( 40- 70)	0.14 (0.11-0.18)
			10-25	50 ( 20- 60)	0.12 (0.08-0.16)
			30-40	40 ( 20- 60)	0.10 (0.06-0.13)
		8	3-8	50 ( 40- 70)	0.15 (0.12-0.20)
			10-25	50 ( 20- 60)	0.14 (0.10-0.17)
			30-40	40 ( 20- 50)	0.11 (0.08-0.14)
		10	3-8	50 ( 40- 70)	0.16 (0.12-0.22)
			10-25	50 ( 20- 60)	0.15 (0.12-0.18)
			30-40	40 ( 20- 50)	0.12 (0.10-0.14)
		12	3-8	50 ( 40- 70)	0.18 (0.14-0.24)
			10-25	60 ( 25- 65)	0.17 (0.14-0.19)
			30-40	50 ( 20- 60)	0.14 (0.11-0.15)
		16	3-8	50 ( 40- 70)	0.19 (0.15-0.26)
			10-25	60 ( 25- 65)	0.17 (0.14-0.19)
		20	3-8	50 ( 40- 70)	0.21 (0.16-0.28)

# MPS1

Malzeme	Özellikler	DC	L x DC	Vc	f
K Döküm Demir	≤ 350 MPa	3	3-8	90 ( 60-100)	0.15 (0.10-0.20)
			10-25	90 ( 40-110)	0.19 (0.11-0.26)
			30-40	75 ( 45- 95)	0.15 (0.09-0.21)
		4	3-8	100 ( 70-110)	0.21 (0.12-0.30)
			10-25	90 ( 40-110)	0.22 (0.13-0.33)
			30-40	75 ( 45- 95)	0.18 (0.10-0.26)
		5	3-8	110 ( 80-130)	0.25 (0.15-0.35)
			10-25	90 ( 40-110)	0.28 (0.17-0.39)
			30-40	75 ( 45- 95)	0.22 (0.13-0.31)
		6	3-8	120 ( 90-140)	0.29 (0.18-0.40)
			10-25	100 ( 60-110)	0.30 (0.19-0.41)
			30-40	90 ( 60-110)	0.24 (0.15-0.33)
		8	3-8	140 (100-160)	0.33 (0.20-0.45)
			10-25	100 ( 60-110)	0.33 (0.22-0.44)
			30-40	90 ( 60-100)	0.26 (0.18-0.35)
		10	3-8	150 (100-170)	0.35 (0.20-0.50)
			10-25	100 ( 60-110)	0.35 (0.24-0.46)
			30-40	90 ( 60-100)	0.28 (0.19-0.37)
		12	3-8	160 (100-170)	0.40 (0.20-0.60)
			10-25	120 ( 90-140)	0.37 (0.26-0.48)
30-40	105 ( 65-115)		0.30 (0.21-0.38)		
16	3-8	160 (100-170)	0.43 (0.20-0.65)		
	10-25	120 ( 90-140)	0.40 (0.29-0.48)		
20	3-8	160 (100-170)	0.45 (0.20-0.70)		
K Duktıl Döküm Demir	≤ 450 MPa	3	3-8	80 ( 50- 90)	0.12 (0.08-0.16)
			10-25	90 ( 40-110)	0.17 (0.10-0.24)
			30-40	30 ( 20- 50)	0.14 (0.08-0.19)
		4	3-8	90 ( 60-100)	0.17 (0.10-0.24)
			10-25	90 ( 40-110)	0.20 (0.12-0.30)
			30-40	30 ( 20- 50)	0.16 (0.10-0.24)
		5	3-8	90 ( 70-120)	0.21 (0.14-0.28)
			10-25	90 ( 40-110)	0.25 (0.15-0.35)
			30-40	30 ( 20- 50)	0.20 (0.12-0.28)
		6	3-8	100 ( 80-130)	0.25 (0.16-0.34)
			10-25	100 ( 60-110)	0.27 (0.17-0.37)
			30-40	40 ( 30- 60)	0.22 (0.14-0.30)
		8	3-8	120 ( 90-150)	0.28 (0.18-0.38)
			10-25	100 ( 60-110)	0.30 (0.20-0.40)
			30-40	40 ( 30- 60)	0.24 (0.16-0.32)
		10	3-8	130 ( 90-160)	0.29 (0.18-0.40)
			10-25	100 ( 60-110)	0.32 (0.22-0.42)
			30-40	40 ( 30- 60)	0.26 (0.18-0.34)
		12	3-8	140 ( 90-160)	0.31 (0.18-0.44)
			10-25	120 ( 90-140)	0.34 (0.24-0.44)
30-40	50 ( 40- 70)		0.27 (0.19-0.35)		
16	3-8	140 ( 90-160)	0.33 (0.18-0.48)		
	10-25	120 ( 90-140)	0.36 (0.26-0.46)		
20	3-8	140 ( 90-160)	0.35 (0.18-0.52)		

# MPS1

Malzeme	Özellikler	DC	L x DC	Vc	f
K Duktıl Döküm Demir	≤ 800 MPa	3	3-8	60 ( 40- 80)	0.09 (0.06-0.12)
		4	3-8	70 ( 50- 90)	0.13 (0.08-0.18)
		5	3-8	70 ( 60-100)	0.17 (0.12-0.22)
		6	3-8	80 ( 70-110)	0.20 (0.14-0.26)
		8	3-8	100 ( 80-130)	0.23 (0.16-0.30)
		10	3-8	110 ( 80-140)	0.24 (0.16-0.32)
		12	3-8	110 ( 80-140)	0.25 (0.16-0.34)
		16	3-8	110 ( 80-140)	0.27 (0.16-0.38)
		20	3-8	110 ( 80-140)	0.28 (0.16-0.40)

# MPS1

## ÇALIŞMA KILAVUZU

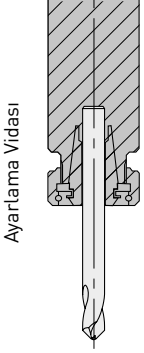
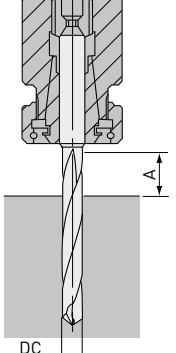
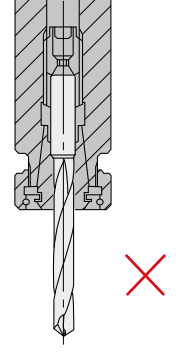
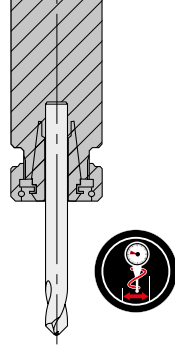
DELME UCUNU TUTTURMA	DELME UCU UZUNLUĞU	DELME UCUNU TAKMA	TAKMA TOLERANSI
			
Baskı yatağı türü halka matkap kovani, delme ucunu sabit tutar.	$A \geq DC \times 1.5$	Oluklu alanlara kelepçelemeyin.	Eksantriklik $\leq 0,03\text{mm}$

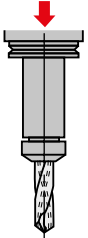
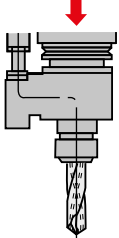
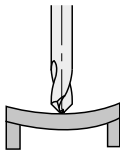
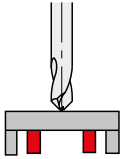
KESİNTİSİZ SOĞUTMA SUYU TÜRÜ	SOĞUTMA SUYU KULLANIMI	İNCE ÇALIŞMA PARÇASI	KESİNTİYE UĞRAYAN KESİM
<p>Mil Kesintisiz Soğutma Suyu Türü</p>  <p>Devirli Soğutma Suyu Makinesi Türü</p> 	<ol style="list-style-type: none"><li>Küçük çaplı delme uçlarının yağ deliğine küçük talaş parçacıkları sıkışır. Koruyucu bir önlem olarak daima ince elekli filtre kullanın.</li><li>Kir ve toz parçacıkları eski soğutma suyundaki yağ yapışır ve etkili akışı önler. Düzenli soğutma suyu değişimi önerilir.</li></ol>	<p>×</p>  <p>Bükülme Oluşursa</p> <p>○</p>  <p>Çalışma Parçasını Destekleyin</p>	<p>Tek Süreç</p> <p>○ 1. Kesintili parçayı delerken ilerlemesi azaltın.</p> <p>Önceden Makine ile İşleme Gerektilir</p> <p>△ 1. Delmeden önce uç frezeli pul yatağı.</p>
Soğutma suyu basıncı yaklaşık 0,5 - 1 MPa'dır (<math>\phi 5:2-3\text{ MPa}</math>).			

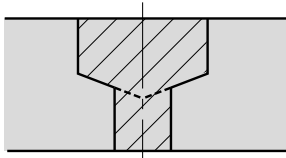
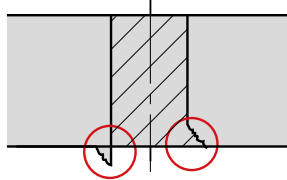
KADEMELİ DELİKLER	ÇAPAKLANMA VE ÇALIŞMA PARÇASINDA YONGALANMA
	
<ol style="list-style-type: none"><li>İki işlemi ayırın.</li><li>Önce daha büyük deliği delin.</li><li>Hem şamfer hem de pul yatağının makine ile işlenmesi için bir takım, sipariş üzerine üretilebilir.</li></ol>	<ol style="list-style-type: none"><li>Delik çıkışında ilerleme oranını %50 oranında azaltın.</li><li>45° şamfer ekleyin.</li><li>Nokta açısını değiştirin.</li></ol>

# MPS1

## UZUN TİP MATKAP UCU NASIL KULLANILIR

### BİR KÖR DELİK DELME

#### 1. Bir pilot deliği delme



1. Süper uzun tipten daha büyük (yassı) bir uç açılı bir matkap ucu kullanın. Mitsubishi MPS1 (PC) tipi önerilir.
2. Yataklama için yüksek hassasiyetli ön deliğin delindiğinden emin olun.
3. Delme ucu derinliği : Yaklaşık 1DC veya daha derin. (Süper uzun tipin uzunluğuna göre pilot deliği derinliğini ayarlayın.)

#### 2. Uzun tip matkap ucu ile ilk kesme

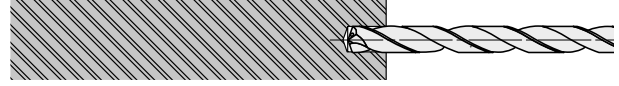

1. Pilot deliğe düşük devirde nüfuz edin. (Kesme hızı 20-30 m/dak, besleme oranı 0.2-0.3 mm/dev)
2. Uzun tip matkap ucunu pilot delik tabanına 1-3 mm kala durdurun.

#### 3. Derin deliği delme

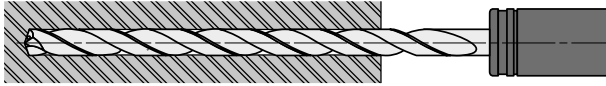

1. Önerilen hızda ve step yapmaksızın (kesintisiz ilerleme) ilerlemede kesmeye başlayın.

#### 4. Matkap ucunu geriye çekme

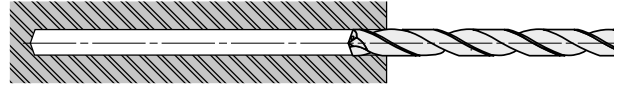

1. Delmeden sonra, kesme devrini delik sonundan yaklaşık 1-2 mm geriye çekin. (Kesme hızı yaklaşık 20-30 m/dak)
2. 3000 mm/dak ilerleme hızı ile matkap ucunu pilot Delik Derinliği başlangıç noktasına geri çekin.
3. Son olarak, 20-30 m/dak kesme hızında ve 0.2-0.3 mm/dev ilerleme oranıyla deliği tamamlayın.

### DÜZENSİZ YÜZEYLERDE VEYA AÇILARDA DELME VE BOŞA ÇIKMA

#### 1. Spot yüzey açma



1. Parmak freze ucu veya spot yüzey açma özellikli matkap ucu kullanarak düzensiz bir yüzey üzerinde bir düzlük işleyin. Gerekli derin delik çapı ile aynı boyutta bir spot yüzey çapı elde edin.

#### 2. Bir pilot deliği delme

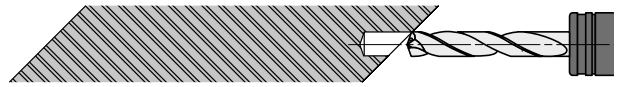

1. Süper uzun tipten daha büyük (yassı) bir uç açılı bir matkap ucu kullanın. Mitsubishi MPS1 (PC) tipi önerilir.
2. Yataklama için yüksek hassasiyetli deliğin delindiğinden emin olun.
3. Matkap ucu derinliği : Yaklaşık 1DC veya daha derin. (Süper uzun tipin uzunluğuna göre pilot deliği derinliğini ayarlayın.)

#### 3. Uzun tip matkap ucu ile ilk kesme

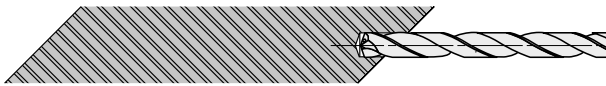

1. Pilot deliğe düşük devirde nüfuz edin. (Kesme hızı 20-30 m/dak, ilerleme oranı 0.2-0.3 mm/dev)
2. Uzun tip matkap ucunu pilot delik tabanına 1-3 mm kala durdurun.

#### 4. Derin deliği delme

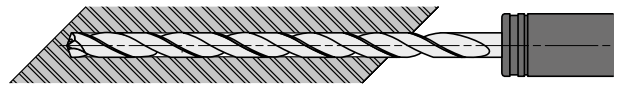

1. Önerilen hızda ve step yapmaksızın (kesintisiz ilerleme) ilerlemede kesmeye başlayın.
2. Kör delik boyunca normal ilerleme hızı ile ilerleyin.

#### 5. Boşa çıkma

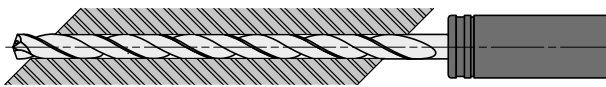

1. Boşa çıkma işlemi sırasında, kesme kenarı hasar görebilir.
2. 0.05-0.1 mm/dev ilerleme oranı önerilir.

#### 6. Matkap ucunu geriye çekme

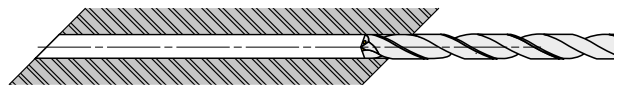

1. 3000mm/dak ilerleme oranında delme ucunu pilot Delik Derinliği başlangıç noktasına geri çekin.
2. Son olarak 20-30 m/dak kesme hızı ve 0.2-0.3 mm/dev ilerleme oranıyla deliği bitirin.



---

# NOTLAR

---

---

---

---

---

---

---

---

---

---

---

---

---

---

---

---

---

---

---

---

---

---

---

---

---

---

---

---

---

---

---

---

---

---









**GERMANY**

MMC HARTMETALL GMBH  
Comeniusstr. 2 . 40670 Meerbusch  
Phone +49 2159 91890 . Fax +49 2159 918966  
Email admin@mmchg.de

**U.K.**

MMC HARDMETAL U.K. LTD.  
Mitsubishi House . Galena Close . Tamworth . Staffs. B77 4AS  
Phone +44 1827 312312 . Fax +44 1827 312314  
Email sales@mitsubishicarbide.co.uk

**SPAIN**

MITSUBISHI MATERIALS ESPAÑA, S.A.  
Calle Emperador 2 . 46136 Museros/Valencia  
Phone +34 96 1441711 . Fax +34 96 1443786  
Email comercial@mmevalencia.es

**FRANCE**

MMC METAL FRANCE S.A.R.L.  
6, Rue Jacques Monod . 91400 Orsay  
Phone +33 1 69 35 53 53 . Fax +33 1 69 35 53 50  
Email mmfsales@mmc-metal-france.fr

**POLAND**

MMC HARDMETAL POLAND SP. Z O.O  
Al. Armii Krajowej 61 . 50-541 Wrocław  
Phone +48 71335 1620 . Fax +48 71335 1621  
Email sales@mitsubishicarbide.com.pl

**RUSSIA**

MMC HARDMETAL OOO LTD.  
Electrozavodskaya St. 24 . build. 3 . Moscow . 107023  
Phone +7 495 725 58 85 . Fax +7 495 981 39 79  
Email info@mmc-carbide.ru

**ITALY**

MMC ITALIA S.R.L.  
Via Montefeltro 6/A . 20156 Milano  
Phone +39 0293 77031 . Fax +39 0293 589093  
Email info@mmc-italia.it

**TURKEY**

MMC HARTMETALL GMBH ALMANYA - İZMİR MERKEZ ŞUBESİ  
Adalet Mahallesi Anadolu Caddesi No: 41-1 . 15001 35580 Bayraklı /İzmir  
Phone +90 232 5015000 . Fax +90 232 5015007  
Email info@mmchg.com.tr

[www.mitsubishicarbide.com](http://www.mitsubishicarbide.com) | [www.mmc-hardmetal.com](http://www.mmc-hardmetal.com)

DAĞITICI:

□

□

L

┘